



Lecture 41. Constituent Lidar (4)

Multi-wavelength Raman DIAL

- ❑ Review conventional DIAL
- ❑ Raman DIAL for Ozone Measurement
- ❑ Rotational Vibrational-Rotational (RVR) Raman DIAL
- ❑ Multiwavelength (Raman) DIAL
- ❑ Comparison of Constituent Lidar Techniques
- ❑ Summary for Constituent Lidar



Lidar Equation for DIAL

- DIAL lidar equation

$$P_S(\lambda, R) = P_L(\lambda) \left[\beta_{scatter}(\lambda, R) \Delta R \right] \left(\frac{A}{R^2} \right) \exp \left[-2 \int_0^R \bar{\alpha}(\lambda, r) dr \right] \\ \times \exp \left[-2 \int_0^R \sigma_{abs}(\lambda, r) n_c(r) dr \right] \left[\eta(\lambda) G(R) \right] + P_B$$

Extinction caused by interested constituent extinction (absorption)

Extinction caused by other molecules and aerosols

- Compared to resonance fluorescence, the main difference in DIAL is that the backscatter coefficient is from the elastic-scattering from air molecules and aerosols, not from the fluorescence of interested molecules.

$$\beta_{Scatter}(\lambda, R) = \beta_{aer}(\lambda, R) + \beta_{mol}(\lambda, R)$$

- The parameter in the DIAL equation

$$\bar{\alpha}(\lambda, r) = \alpha_{aer}(\lambda, r) + \alpha_{mol}(\lambda, r) + \sigma_{IG}(\lambda, r) n_{IG}(r)$$

Aerosol Extinction

Air Molecule Extinction

Interference gas absorption



Conventional DIAL Ozone Measurement

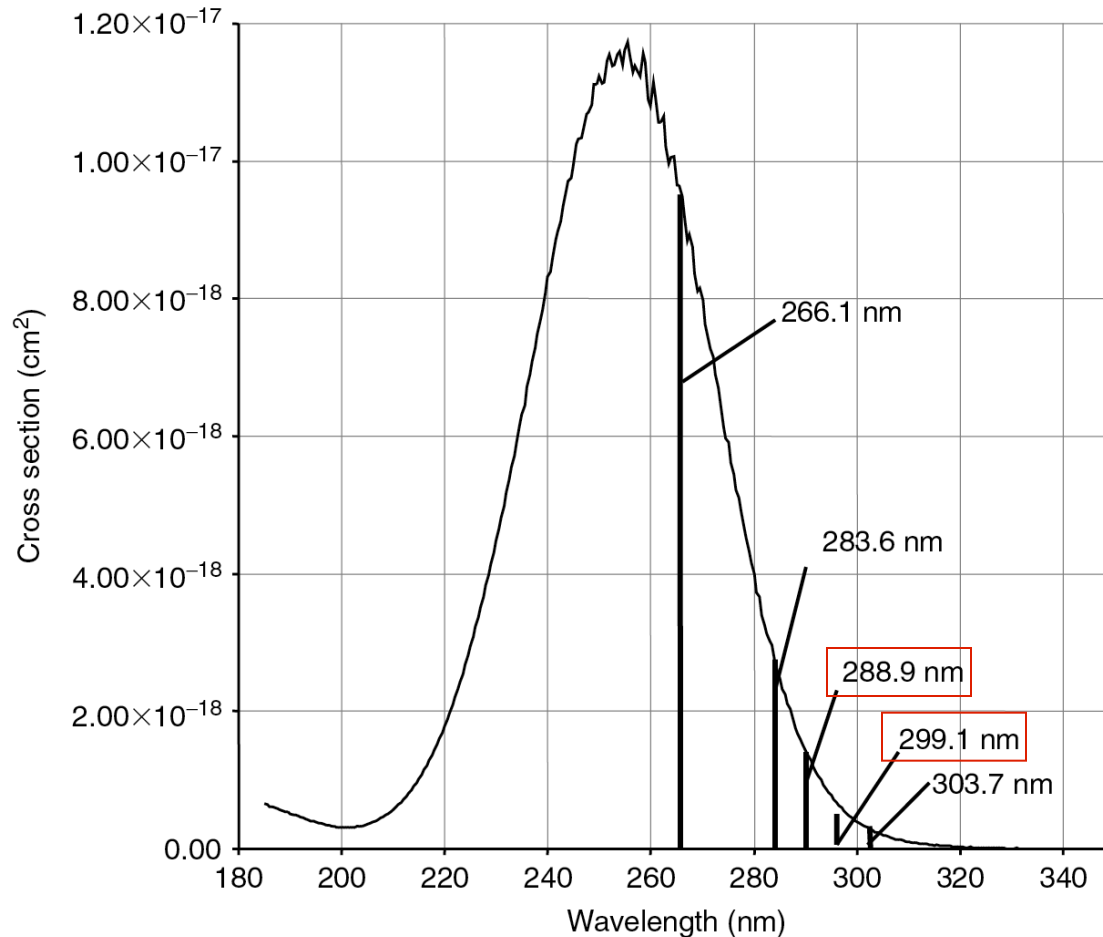

$$\lambda_{ON} = 288.9 \text{ nm}$$

$$\lambda_{OFF} = 299.1 \text{ nm}$$

Figure 4.1 Ozone absorption spectrum in the UV: the Raman shifted wavelengths given in Table 4.2 are highlighted in this figure.

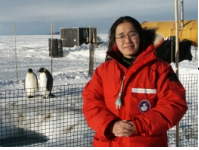

Conventional DIAL Solutions

$$n_c(R) = \frac{1}{2\Delta\sigma_{abs}} \frac{d}{dR} \left\{ \begin{array}{l} \ln \left[\frac{P_S(\lambda_{OFF}, R) - P_B}{P_S(\lambda_{ON}, R) - P_B} \right] \\ - \ln \left[\frac{P_L(\lambda_{OFF})\eta(\lambda_{OFF})}{P_L(\lambda_{ON})\eta(\lambda_{ON})} \right] \\ - \ln \left[\frac{\beta_{aer}(\lambda_{OFF}, R) + \beta_{mol}(\lambda_{OFF}, R)}{\beta_{aer}(\lambda_{ON}, R) + \beta_{mol}(\lambda_{ON}, R)} \right] \end{array} \right\} - \frac{1}{\Delta\sigma_{abs}} \left\{ \begin{array}{l} [\alpha_{aer}(\lambda_{ON}, R) - \alpha_{aer}(\lambda_{OFF}, R)] \\ + [\alpha_{mol}(\lambda_{ON}, R) - \alpha_{mol}(\lambda_{OFF}, R)] \\ + [\sigma_{IG}(\lambda_{ON}, R) - \sigma_{IG}(\lambda_{OFF}, R)]n_{IG} \end{array} \right\}$$

All terms non-range dependent vanish after the derivative d/dR

Introducing large error when large aerosol gradient or IG exists⁴

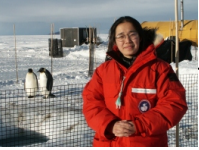

Ozone Raman DIAL

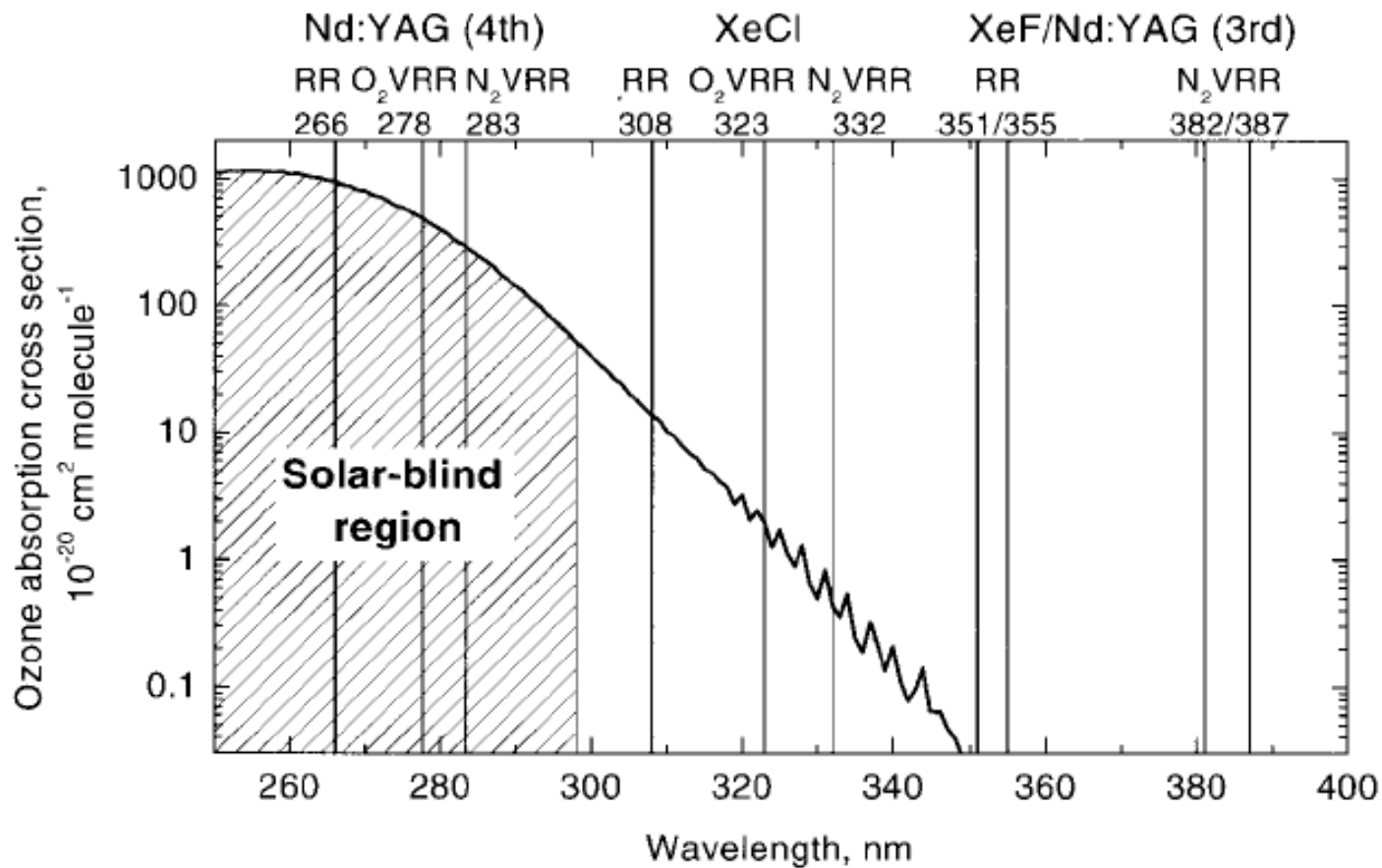
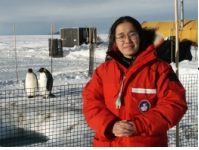
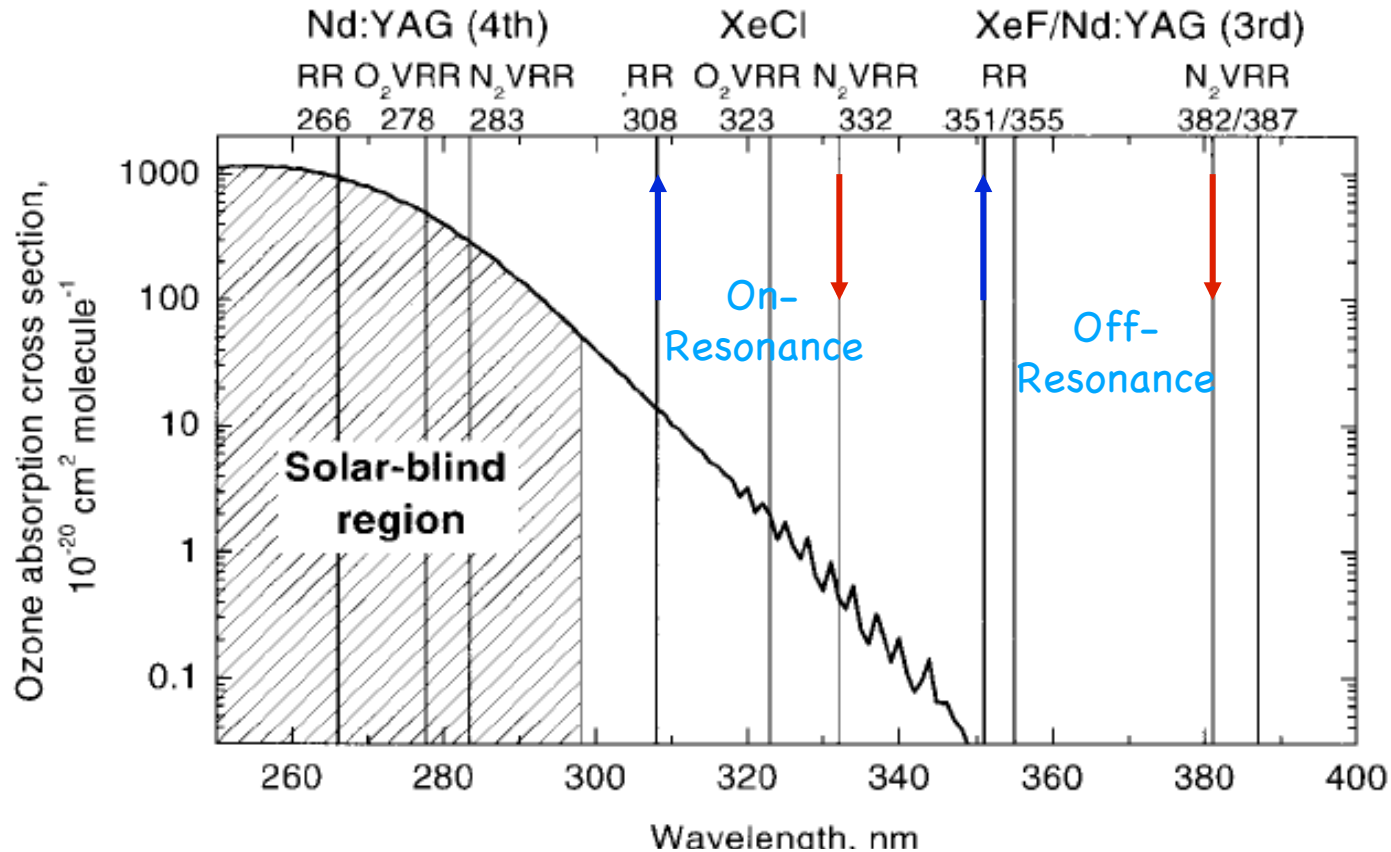

Fig. 9.5. Ozone absorption cross section and wavelengths applied in the ozone Raman DIAL technique for upper tropospheric and stratospheric measurements ($\lambda > 300$ nm) and for boundary-layer measurements in the solar-blind region ($\lambda < 300$ nm).



Conventional Raman DIAL for O_3 Measurements in Clouds



Conventional Raman DIAL uses two primary wavelengths transmitted (e.g., 308 and 351 nm) into the atmosphere and ozone is calculated from the differential absorption of the corresponding Raman return signals of molecular N_2 (e.g., 332 and 382 nm).

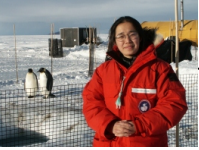

Raman DIAL Equations

□ Raman channels (e.g., from N_2 Raman inelastic scattering, instead of elastic scattering from air molecules or aerosols),

$$\begin{aligned}
 P_S(\lambda_{\text{Ref}}^{\text{ON}}, R) &= P_L(\lambda_0^{\text{ON}}) \left[\beta_{\text{Raman}}(\lambda_0^{\text{ON}}, \lambda_{\text{Ref}}^{\text{ON}}, R) \Delta R \right] \left(\frac{A}{R^2} \right) \\
 &\times \exp \left[- \int_0^R \left(\alpha_{\text{aer}}(\lambda_0^{\text{ON}}, r) + \alpha_{\text{aer}}(\lambda_{\text{Ref}}^{\text{ON}}, r) + \alpha_{\text{mol}}(\lambda_0^{\text{ON}}, r) + \alpha_{\text{mol}}(\lambda_{\text{Ref}}^{\text{ON}}, r) \right) dr \right] \\
 &\times \exp \left[- \int_0^R \left(\sigma_{\text{IG}}(\lambda_0^{\text{ON}}, r) + \sigma_{\text{IG}}(\lambda_{\text{Ref}}^{\text{ON}}, r) \right) n_{\text{IG}} dr \right] \\
 &\times \exp \left[- \int_0^R \left(\sigma_{\text{abs}}(\lambda_0^{\text{ON}}, r) + \sigma_{\text{abs}}(\lambda_{\text{Ref}}^{\text{ON}}, r) \right) n_c(r) dr \right] \left[\eta(\lambda_{\text{Ref}}^{\text{ON}}) G(R) \right] + P_B
 \end{aligned}$$

$$\begin{aligned}
 P_S(\lambda_{\text{Ref}}^{\text{OFF}}, R) &= P_L(\lambda_0^{\text{OFF}}) \left[\beta_{\text{Raman}}(\lambda_0^{\text{OFF}}, \lambda_{\text{Ref}}^{\text{OFF}}, R) \Delta R \right] \left(\frac{A}{R^2} \right) \\
 &\times \exp \left[- \int_0^R \left(\alpha_{\text{aer}}(\lambda_0^{\text{OFF}}, r) + \alpha_{\text{aer}}(\lambda_{\text{Ref}}^{\text{OFF}}, r) + \alpha_{\text{mol}}(\lambda_0^{\text{OFF}}, r) + \alpha_{\text{mol}}(\lambda_{\text{Ref}}^{\text{OFF}}, r) \right) dr \right] \\
 &\times \exp \left[- \int_0^R \left(\sigma_{\text{IG}}(\lambda_0^{\text{OFF}}, r) + \sigma_{\text{IG}}(\lambda_{\text{Ref}}^{\text{OFF}}, r) \right) n_{\text{IG}} dr \right] \\
 &\times \exp \left[- \int_0^R \left(\sigma_{\text{abs}}(\lambda_0^{\text{OFF}}, r) + \sigma_{\text{abs}}(\lambda_{\text{Ref}}^{\text{OFF}}, r) \right) n_c(r) dr \right] \left[\eta(\lambda_{\text{Ref}}^{\text{OFF}}) G(R) \right] + P_B
 \end{aligned}$$

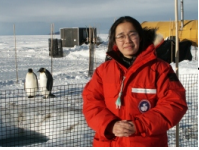

Solution for Raman DIAL Equations

□ From the two Raman reference channel equations, we obtain the number density of the constituent that we are interested in

$$n_c(R) = \frac{1}{\Delta\sigma_{abs}} \frac{d}{dR} \left\{ \begin{array}{l} \ln \left[\frac{P_S(\lambda_{Ref}^{OFF}, R) - P_B}{P_S(\lambda_{Ref}^{ON}, R) - P_B} \right] \\ - \ln \left[\frac{P_L(\lambda_0^{OFF}) \eta(\lambda_{Ref}^{OFF})}{P_L(\lambda_0^{ON}) \eta(\lambda_{Ref}^{ON})} \right] \\ - \ln \left[\frac{\beta_{Raman}(\lambda_{Ref}^{OFF}, R)}{\beta_{Raman}(\lambda_{Ref}^{ON}, R)} \right] \\ \Delta\alpha_{aer}(R) \\ + \Delta\alpha_{mol}(R) \\ + \Delta\sigma_{IG}(R)n_{IG} \end{array} \right\} \begin{array}{l} A \\ B \\ C \\ D \\ E \\ F \end{array}$$

□ Here, the Δ expressions consist of four terms each

$$\Delta\xi = \xi(\lambda_0^{ON}) + \xi(\lambda_{Ref}^{ON}) - \xi(\lambda_0^{OFF}) - \xi(\lambda_{Ref}^{OFF})$$

with

$$\xi = \sigma_{abs}, \alpha_{aer}, \alpha_{mol}, \sigma_{IG}$$



Solution in Ozone Case

- Term B can be measured and it is range-independent, so the derivative is zero,
- Term C is only concerned about molecule Raman scattering, so can be calculated.
- Term D will be determined through using the Raman channel at OFF wavelength and introducing Angstrom exponent.
- Term E is concerned about molecule Rayleigh scattering, so can be calculated from atmosphere temperature and pressure.
- Term F can be minimized through choosing proper wavelengths, thus, can be ignored.

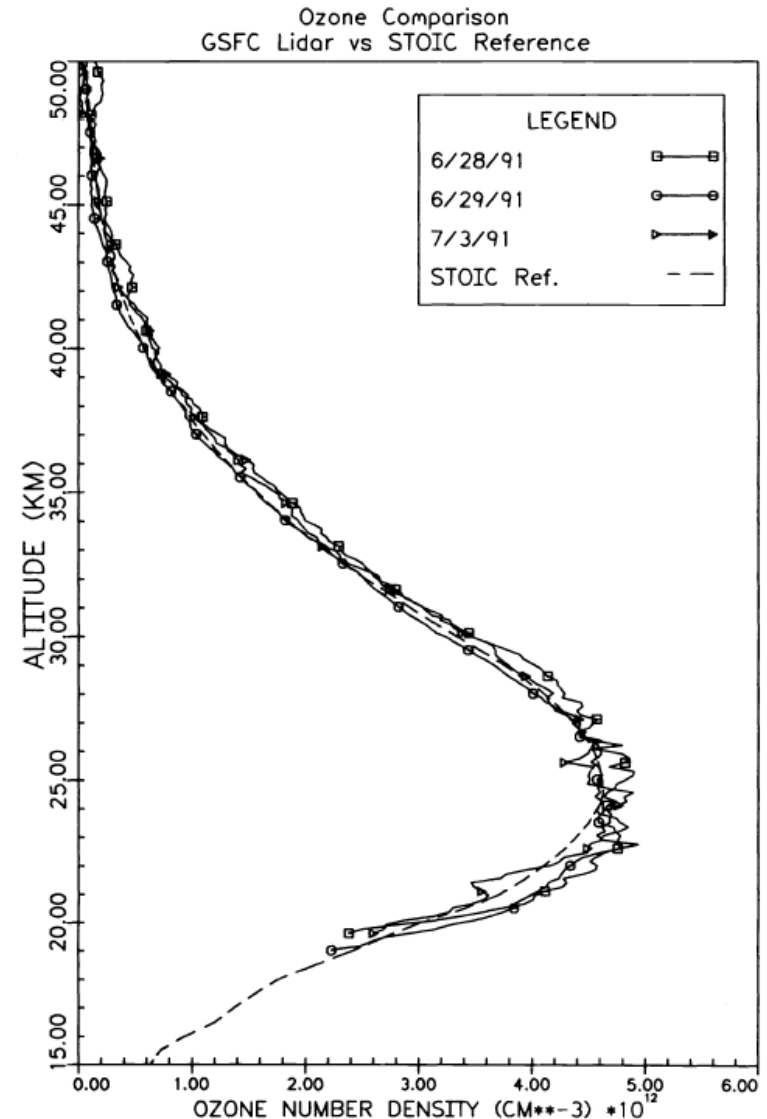
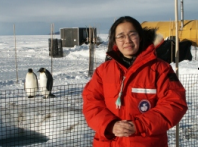
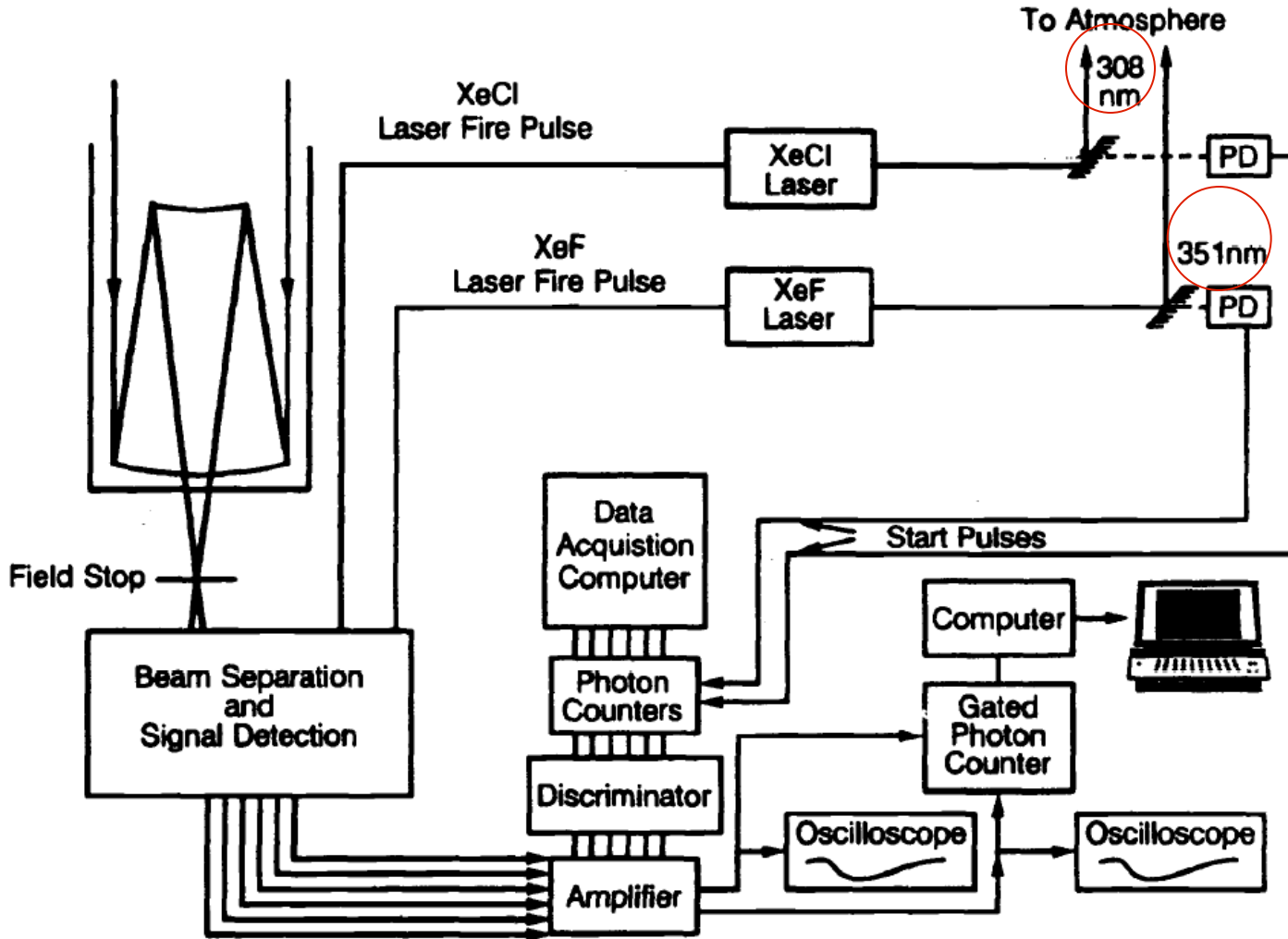

Fig. 6 GSFC lidar ozone profiles taken at JPL-TMO during June and July 1991 using the mechanical chopper.



Ozone Raman DIAL Instrumentation



Return Signals -

On-line: 332 nm (N_2 Raman scattering from 308 nm)

Off-line: 382 nm (N_2 Raman scattering from 351 nm)



Ozone Raman DIAL Receiver

Return signals

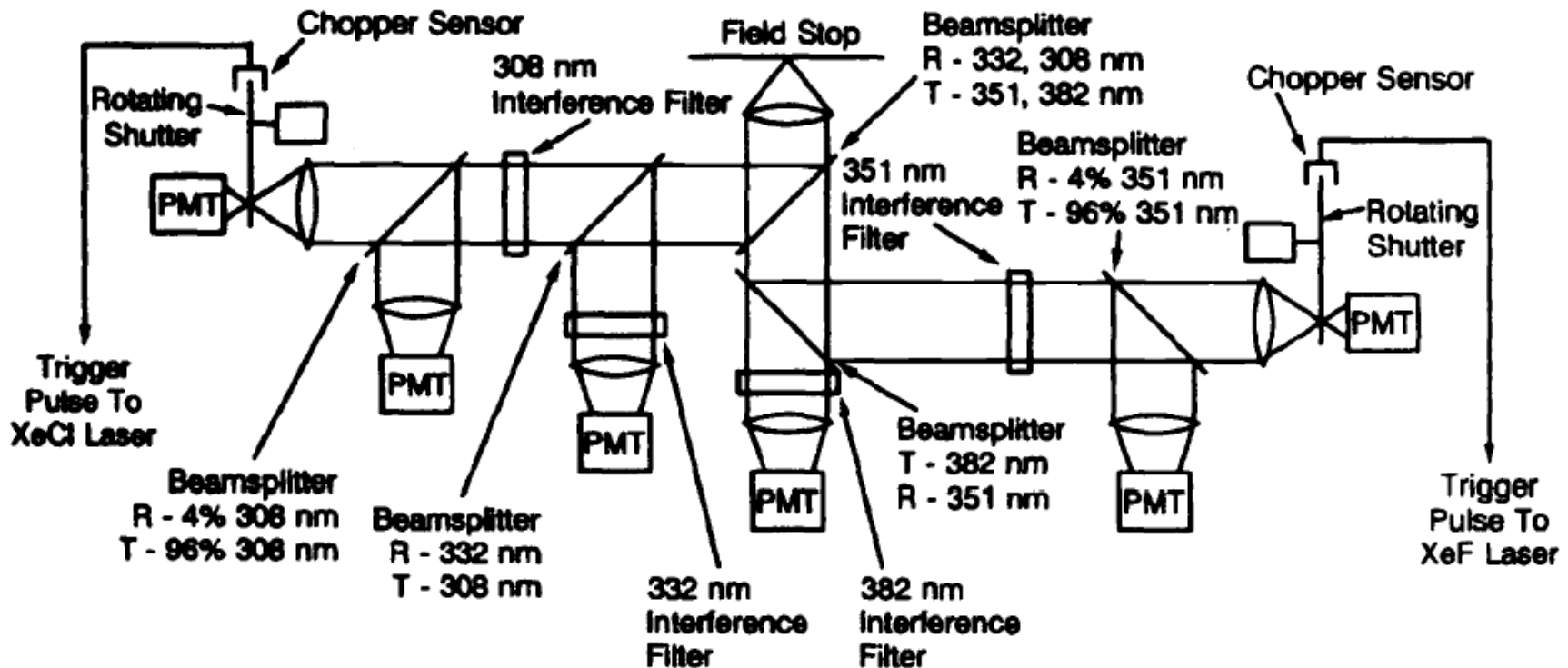

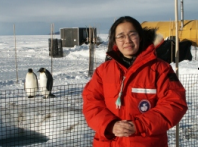

RVR Raman DIAL for O₃ Measurement

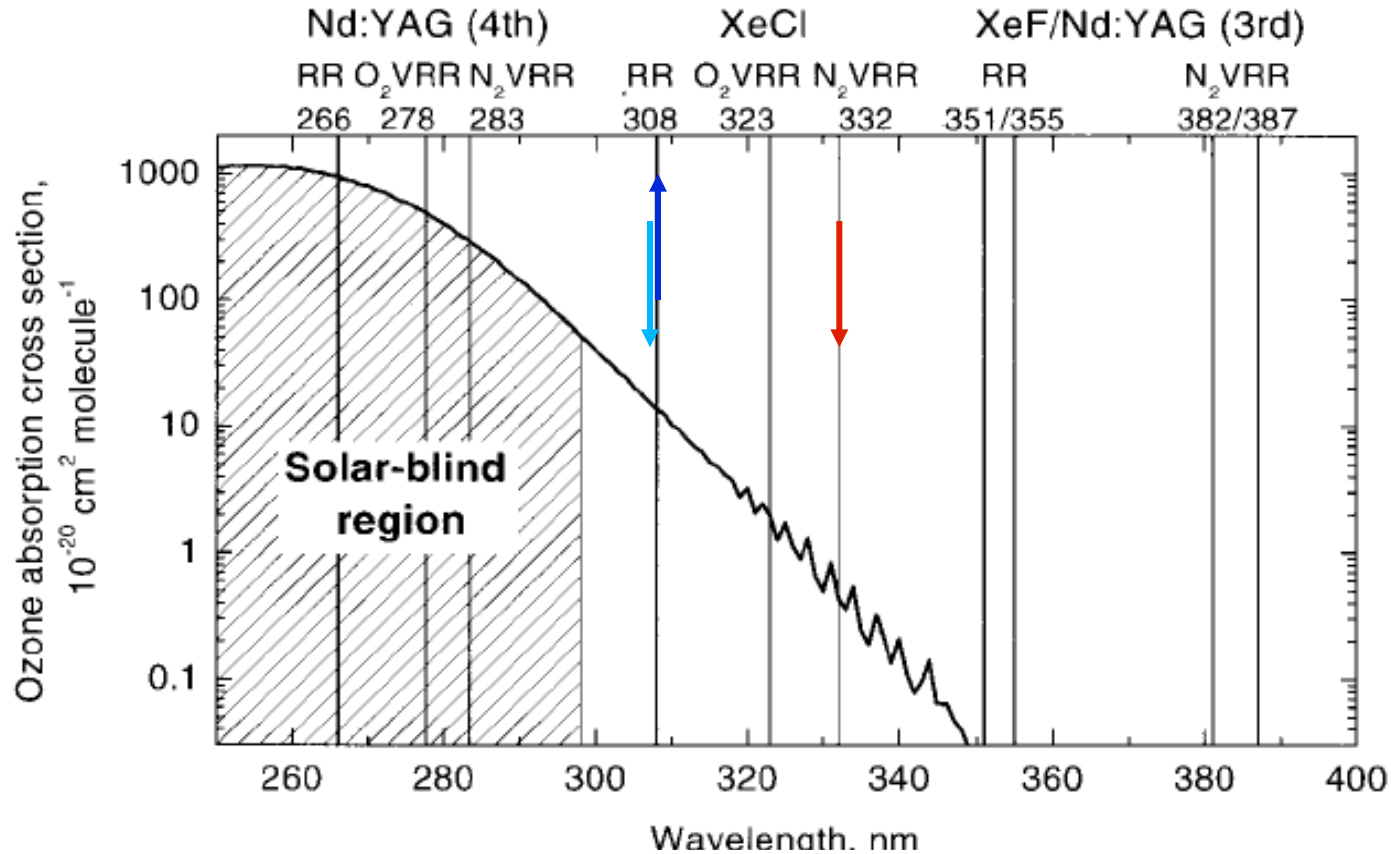

Rotational Vibrational-Rotational Raman DIAL transmits single primary wavelength (e.g., 308 nm) into the atmosphere and then ozone measurement is based on differential absorption of ozone between the purely rotational Raman (RR) return signals from N₂ (307 nm) and O₂ (307 nm) as the on-resonance wavelength, and the vibrational-rotational Raman (VRR) return signals from N₂ (332 nm) or O₂ (323 nm) as the off-resonance wavelength.



Rotational Vibrational-Rotational (RVR) Raman DIAL with Single Laser

Table 1. Parameters of the Conventional Raman DIAL and the RVR Raman DIAL's^a

Lidar	On-Resonance		Off-Resonance			
	Raman Wavelength (nm)	λ_L (nm)	Raman Wavelength (nm)	λ_L (nm)	$\Delta\lambda$ (nm)	$\Delta C_{O_3}^{abs}$ (10^{-24} m^2)
O ₂ RVR Raman DIAL	307	308	323	308	16	11.7
N ₂ RVR Raman DIAL	307	308	332	308	25	12.3
Raman DIAL	332	308	387	355	79	12.4

^a $\Delta\lambda$, maximum spectral separation of the signals used for the measurements. Differential ozone absorption cross sections ($\Delta C_{O_3}^{abs}$) are calculated from Ref. 13 ($T = 226 \text{ K}$). Wavelength values are rounded to full nanometers.

The RVR Raman DIAL measurement yields the numbers $N(\lambda, z)$ of lidar return photons from distance z at the rotational Raman wavelength λ_R of molecular oxygen and nitrogen and at the vibrational-rotational Raman wavelength λ_{VR} of O₂ or N₂, if light of the primary wavelength λ_L is transmitted. When absorption by particles and trace gases other than ozone is neglected, a condition satisfied for cirrus measurements in the free troposphere,³ the RVR Raman DIAL ozone molecule number density $n(z)$ in the single-scattering approximation is given by

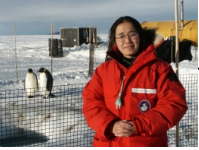

RVR Raman DIAL

$$n(z) = RVRN - RVRM - RVRP, \quad (1)$$

where

$$RVRN = \frac{(d/dz)\ln[N(\lambda_{VR}, z)/N(\lambda_R, z)]}{C_{O_3}^{abs}(\lambda_R, T) - C_{O_3}^{abs}(\lambda_{VR}, T)},$$

$$RVRM = \frac{\alpha_{mol}^{sca}(\lambda_R, z) - \alpha_{mol}^{sca}(\lambda_{VR}, z)}{C_{O_3}^{abs}(\lambda_R, T) - C_{O_3}^{abs}(\lambda_{VR}, T)},$$

$$RVRP = \frac{\alpha_{par}^{sca}(\lambda_R, z) - \alpha_{par}^{sca}(\lambda_{VR}, z)}{C_{O_3}^{abs}(\lambda_R, T) - C_{O_3}^{abs}(\lambda_{VR}, T)}.$$

Here $C_{O_3}^{abs}(\lambda, T)$ is the ozone absorption cross section at temperature T , and $\alpha_{mol}^{sca}(\lambda, z)$ and $\alpha_{par}^{sca}(\lambda, z)$ are the Rayleigh extinction and the single-scattering particle extinction coefficient, respectively. Similar expressions, RDN , RDM , and RDP , have been derived for conventional Raman DIAL.⁴

[Reichardt et al., *Applied Optics*, 39, 6072-6079, 2000]

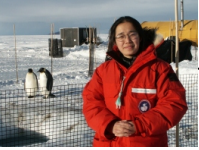

Single-Laser RVR Raman DIAL

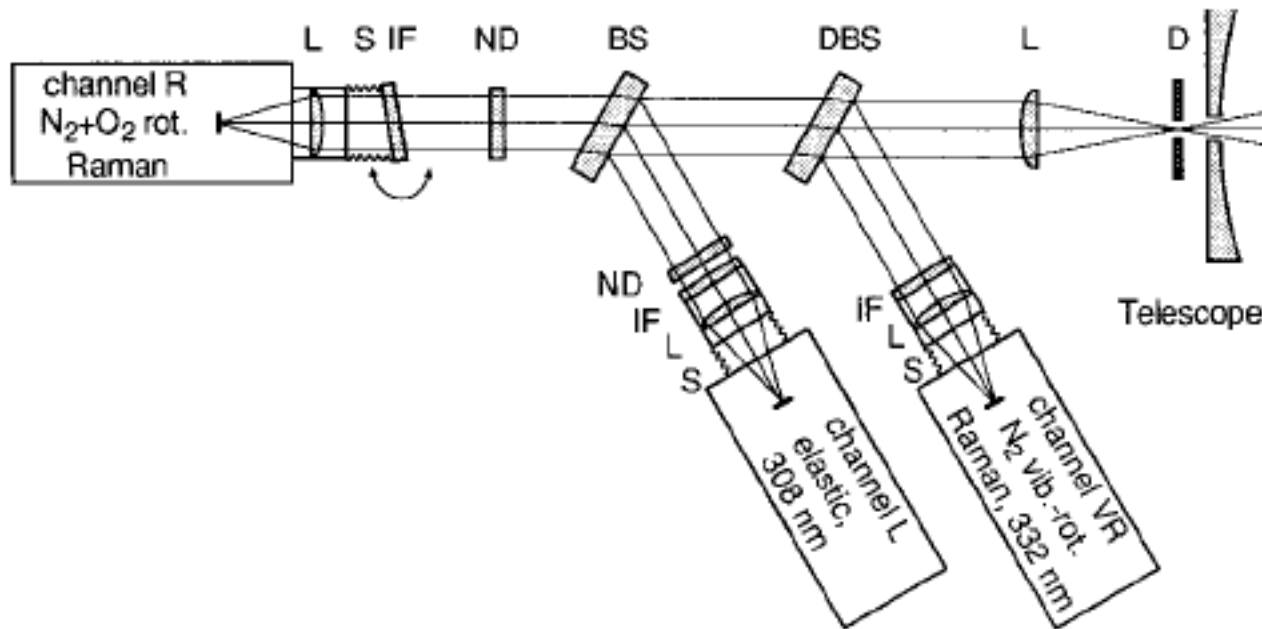
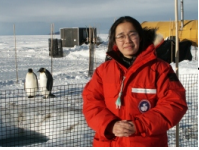

Fig. 3. RVR Raman DIAL receiver: D, diaphragm; L, lens; DBS, dichroic beam splitter; BS, beam splitter; ND, neutral-density filter; IF, interference filter; S, flexible shield. Atmospheric rotational Raman, elastic, and N_2 vibrational-rotational Raman backscattering signals are detected in channels R, L, and VR. The center wavelength of the channel-R interference filter can be tuned by rotating the filter around the vertical axis.



RVR Raman DIAL Equation

- For the elastic DIAL channel at ON-resonance wavelength 308 nm,

$$P_S(\lambda_L, R) = P_L(\lambda_L) \left[(\beta_{aer}(\lambda_L, R) + \beta_{mol}(\lambda_L, R)) \Delta R \right] \left(\frac{A}{R^2} \right) \exp \left[-2 \int_0^R (\alpha_{aer}(\lambda_L, r) + \alpha_{mol}(\lambda_L, r)) dr \right] \\ \times \exp \left[-2 \int_0^R \sigma_{IG}(\lambda_L, r) n_{IG} dr \right] \exp \left[-2 \int_0^R \sigma_{abs}(\lambda_L, r) n_c(r) dr \right] \left[\eta(\lambda_L) G(R) \right] + P_B$$

- For the purely rotational Raman channels from N₂ and O₂ at 307 nm,

$$P_S(\lambda_{RR}, R) = P_L(\lambda_L) \left[\beta_{Raman}(\lambda_L, \lambda_{RR}, R) \Delta R \right] \left(\frac{A}{R^2} \right) \\ \times \exp \left[-\int_0^R (\alpha_{aer}(\lambda_L, r) + \alpha_{aer}(\lambda_{RR}, r) + \alpha_{mol}(\lambda_L, r) + \alpha_{mol}(\lambda_{RR}, r)) dr \right] \\ \times \exp \left[-\int_0^R (\sigma_{IG}(\lambda_L, r) + \sigma_{IG}(\lambda_{RR}, r)) n_{IG} dr \right] \\ \times \exp \left[-\int_0^R (\sigma_{abs}(\lambda_L, r) + \sigma_{abs}(\lambda_{RR}, r)) n_c(r) dr \right] \left[\eta(\lambda_{RR}) G(R) \right] + P_B$$

The beauty of the RVR Raman DIAL is the utilization of pure rotational Raman (RR) scattering so that aerosol backscatter is excluded in the RR channel. 16



RVR Raman DIAL Equation Continued

- For the vibrational-rotational Raman channel from N_2 at 332 nm,

$$\begin{aligned}
 P_S(\lambda_{VRR}, R) = & P_L(\lambda_L) \left[\beta_{Raman}(\lambda_L, \lambda_{VRR}, R) \Delta R \right] \left(\frac{A}{R^2} \right) \\
 & \times \exp \left[- \int_0^R \left(\alpha_{aer}(\lambda_L, r) + \alpha_{aer}(\lambda_{VRR}, r) + \alpha_{mol}(\lambda_L, r) + \alpha_{mol}(\lambda_{VRR}, r) \right) dr \right] \\
 & \times \exp \left[- \int_0^R \left(\sigma_{IG}(\lambda_L, r) + \sigma_{IG}(\lambda_{VRR}, r) \right) n_{IG} dr \right] \\
 & \times \exp \left[- \int_0^R \left(\sigma_{abs}(\lambda_L, r) + \sigma_{abs}(\lambda_{VRR}, r) \right) n_c(r) dr \right] \left[\eta(\lambda_{VRR}) G(R) \right] + P_B
 \end{aligned}$$

Certainly, the vibrational-rotational Raman (VRR) scattering channel also excludes aerosol backscatter.



Solution for RVR Raman DIAL

From the Rotational Raman (RR) and the Vibrational-Rotational Raman (VRR) equations, the ozone number density can be derived as

$$n_c(R) = \frac{1}{\Delta\sigma_{abs}} \frac{d}{dR} \left\{ \begin{array}{l} \ln \left[\frac{P_S(\lambda_{VRR}, R) - P_B}{P_S(\lambda_{RR}, R) - P_B} \right] \\ - \ln \left[\frac{\eta(\lambda_{VRR})}{\eta(\lambda_{RR})} \right] \\ - \ln \left[\frac{\beta_{Raman}(\lambda_{VRR}, R)}{\beta_{Raman}(\lambda_{RR}, R)} \right] \end{array} \right\} \begin{array}{l} \text{--- A} \\ \text{--- B} \\ \text{--- C} \end{array}$$

$$- \frac{1}{\Delta\sigma_{abs}} \left\{ \begin{array}{l} \Delta\alpha_{aer}(R) \\ + \Delta\alpha_{mol}(R) \\ + \Delta\sigma_{IG}(R)n_{IG} \end{array} \right\} \begin{array}{l} \text{--- D} \\ \text{--- E} \\ \text{--- F} \end{array}$$

Here, the Δ expressions consist of four terms each, but the outgoing laser wavelength terms are cancelled out

$$\Delta\xi = [\xi(\lambda_L) + \xi(\lambda_{RR})] - [\xi(\lambda_L) + \xi(\lambda_{VRR})] = \xi(\lambda_{RR}) - \xi(\lambda_{VRR})$$

with $\xi = \sigma_{abs}, \alpha_{aer}, \alpha_{mol}, \sigma_{IG}$



Challenge in RVR Raman DIAL

- ❑ Term B is range-independent, so the derivative is zero,
- ❑ Term C is only concerned about molecule Raman scattering.
- ❑ Term D will be determined through using the Raman VRR channel and introducing Angstrom exponent.
- ❑ Term E is concerned about molecule Rayleigh scattering, so can be calculated from atmosphere temperature and pressure.
- ❑ Term F can be minimized through choosing proper wavelengths, thus, can be ignored.

The main challenge in RVR Raman DIAL is how to sufficiently suppress the elastic scattering at laser wavelength in the pure rotational Raman (RR) channel, as the wavelength difference is only 1 nm.

Modern interference filter has FWHM of 0.3 nm, but its wing (or tail) can certainly extend to more than 1 nm. Since Rayleigh scattering is about 3 orders of magnitude larger than rotational Raman scattering, the influence from Rayleigh scattering is not easy to be excluded. Thus, RVR Raman DIAL is not easy to be realized.

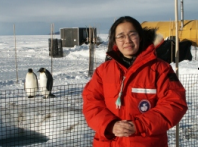

Multiwavelength (Raman) DIAL

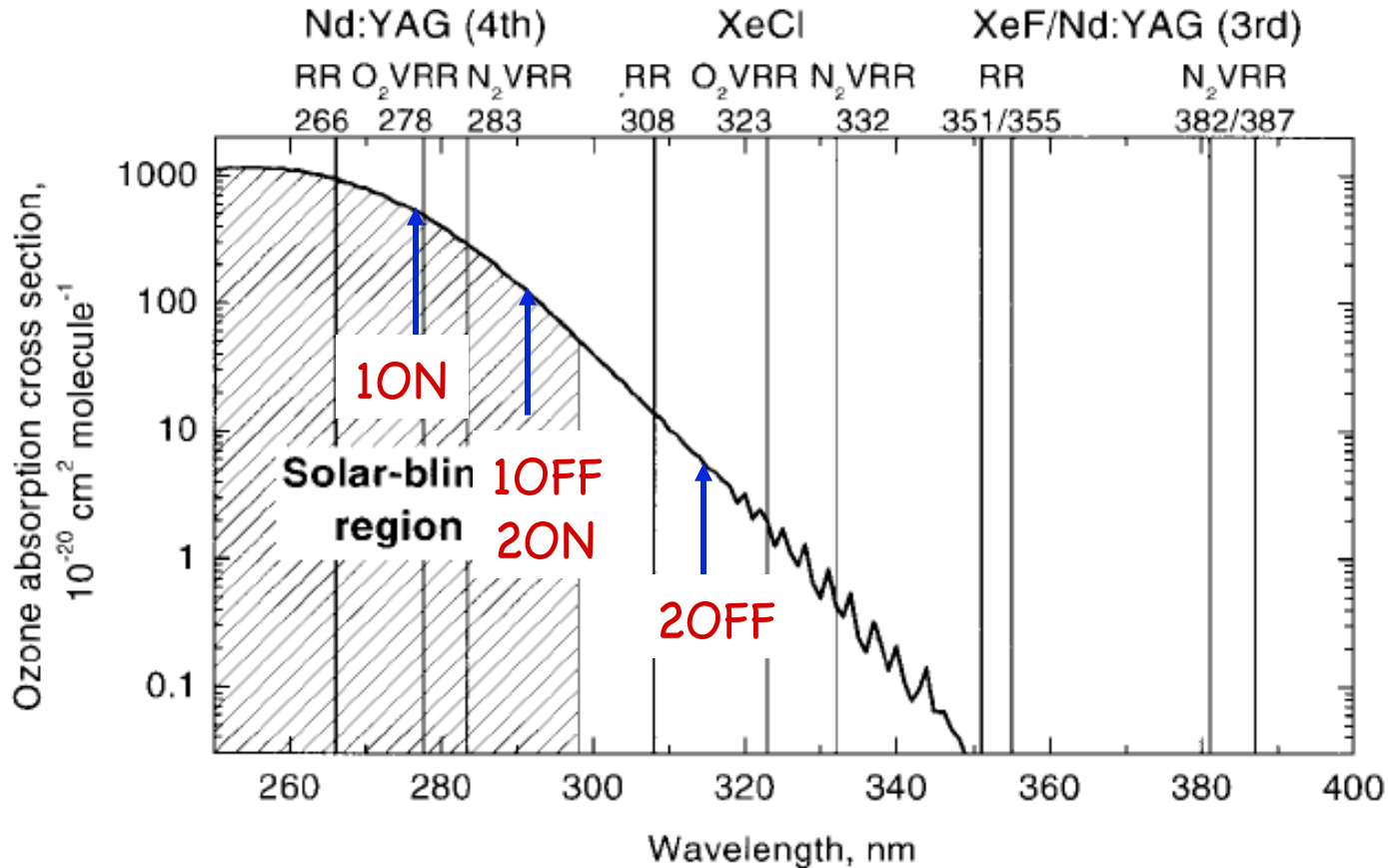

Multiwavelength DIAL uses three or more wavelengths transmitted into the atmosphere and ozone is calculated from the differential absorption of several pairs of elastic scattering signals from air molecules and aerosols. The influence from differential scattering and extinction of aerosols are dramatically decreased by properly choosing wavelengths.

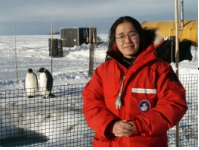

Multiwavelength DIAL Equation

□ For the elastic DIAL channel at 1ON-resonance wavelength,

$$P_S(\lambda_1^{ON}, R) = P_L(\lambda_1^{ON}) \left[\left(\beta_{aer}(\lambda_1^{ON}, R) + \beta_{mol}(\lambda_1^{ON}, R) \right) \Delta R \right] \left(\frac{A}{R^2} \right) \exp \left[-2 \int_0^R \left(\alpha_{aer}(\lambda_1^{ON}, r) + \alpha_{mol}(\lambda_1^{ON}, r) \right) dr \right] \\ \times \exp \left[-2 \int_0^R \sigma_{IG}(\lambda_1^{ON}, r) n_{IG}(r) dr \right] \exp \left[-2 \int_0^R \sigma_{abs}(\lambda_1^{ON}, r) n_c(r) dr \right] \left[\eta(\lambda_1^{ON}) G(R) \right] + P_B$$

□ For the elastic DIAL channel at 1OFF-resonance wavelength,

$$P_S(\lambda_1^{OFF}, R) = P_L(\lambda_1^{OFF}) \left[\left(\beta_{aer}(\lambda_1^{OFF}, R) + \beta_{mol}(\lambda_1^{OFF}, R) \right) \Delta R \right] \left(\frac{A}{R^2} \right) \exp \left[-2 \int_0^R \left(\alpha_{aer}(\lambda_1^{OFF}, r) + \alpha_{mol}(\lambda_1^{OFF}, r) \right) dr \right] \\ \times \exp \left[-2 \int_0^R \sigma_{IG}(\lambda_1^{OFF}, r) n_{IG}(r) dr \right] \exp \left[-2 \int_0^R \sigma_{abs}(\lambda_1^{OFF}, r) n_c(r) dr \right] \left[\eta(\lambda_1^{OFF}) G(R) \right] + P_B$$

□ For the elastic DIAL channel at 2ON-resonance wavelength,

$$P_S(\lambda_2^{ON}, R) = P_L(\lambda_2^{ON}) \left[\left(\beta_{aer}(\lambda_2^{ON}, R) + \beta_{mol}(\lambda_2^{ON}, R) \right) \Delta R \right] \left(\frac{A}{R^2} \right) \exp \left[-2 \int_0^R \left(\alpha_{aer}(\lambda_2^{ON}, r) + \alpha_{mol}(\lambda_2^{ON}, r) \right) dr \right] \\ \times \exp \left[-2 \int_0^R \sigma_{IG}(\lambda_2^{ON}, r) n_{IG}(r) dr \right] \exp \left[-2 \int_0^R \sigma_{abs}(\lambda_2^{ON}, r) n_c(r) dr \right] \left[\eta(\lambda_2^{ON}) G(R) \right] + P_B$$

□ For the elastic DIAL channel at 2OFF-resonance wavelength,

$$P_S(\lambda_2^{OFF}, R) = P_L(\lambda_2^{OFF}) \left[\left(\beta_{aer}(\lambda_2^{OFF}, R) + \beta_{mol}(\lambda_2^{OFF}, R) \right) \Delta R \right] \left(\frac{A}{R^2} \right) \exp \left[-2 \int_0^R \left(\alpha_{aer}(\lambda_2^{OFF}, r) + \alpha_{mol}(\lambda_2^{OFF}, r) \right) dr \right] \\ \times \exp \left[-2 \int_0^R \sigma_{IG}(\lambda_2^{OFF}, r) n_{IG}(r) dr \right] \exp \left[-2 \int_0^R \sigma_{abs}(\lambda_2^{OFF}, r) n_c(r) dr \right] \left[\eta(\lambda_2^{OFF}) G(R) \right] + P_B \quad 21$$

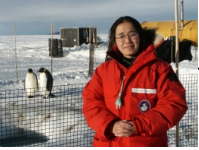

3-Wavelength Dual-DIAL for O_3

□ From above equations, we can derive the following

$$\begin{aligned}
 \ln \left(\frac{P_S(\lambda_1^{ON}, R) - P_B}{P_S(\lambda_1^{OFF}, R) - P_B} \bigg/ \frac{P_S(\lambda_2^{ON}, R) - P_B}{P_S(\lambda_2^{OFF}, R) - P_B} \right) &= \ln \left(\frac{P_L(\lambda_1^{ON}) \eta(\lambda_1^{ON})}{P_L(\lambda_1^{OFF}) \eta(\lambda_1^{OFF})} \bigg/ \frac{P_L(\lambda_2^{ON}) \eta(\lambda_2^{ON})}{P_L(\lambda_2^{OFF}) \eta(\lambda_2^{OFF})} \right) \\
 &+ \ln \left(\frac{\beta_{aer}(\lambda_1^{ON}, R) + \beta_{mol}(\lambda_1^{ON}, R)}{\beta_{aer}(\lambda_1^{OFF}, R) + \beta_{mol}(\lambda_1^{OFF}, R)} \bigg/ \frac{\beta_{aer}(\lambda_2^{ON}, R) + \beta_{mol}(\lambda_2^{ON}, R)}{\beta_{aer}(\lambda_2^{OFF}, R) + \beta_{mol}(\lambda_2^{OFF}, R)} \right) \\
 &- 2 \int_0^R \left[\left(\alpha_{aer}(\lambda_1^{ON}, r) - \alpha_{aer}(\lambda_1^{OFF}, r) \right) - \left(\alpha_{aer}(\lambda_2^{ON}, r) - \alpha_{aer}(\lambda_2^{OFF}, r) \right) \right] dr \\
 &- 2 \int_0^R \left[\left(\alpha_{mol}(\lambda_1^{ON}, r) - \alpha_{mol}(\lambda_1^{OFF}, r) \right) - \left(\alpha_{mol}(\lambda_2^{ON}, r) - \alpha_{mol}(\lambda_2^{OFF}, r) \right) \right] dr \\
 &- 2 \int_0^R \left[\left(\sigma_{IG}(\lambda_1^{ON}, r) - \sigma_{IG}(\lambda_1^{OFF}, r) \right) - \left(\sigma_{IG}(\lambda_2^{ON}, r) - \sigma_{IG}(\lambda_2^{OFF}, r) \right) \right] n_{IG}(r) dr \\
 &- 2 \int_0^R \left[\left(\sigma_{abs}(\lambda_1^{ON}, r) - \sigma_{abs}(\lambda_1^{OFF}, r) \right) - \left(\sigma_{abs}(\lambda_2^{ON}, r) - \sigma_{abs}(\lambda_2^{OFF}, r) \right) \right] n_c(r) dr
 \end{aligned}$$

Three wavelengths form a dual-pair DIAL, with $\lambda_{1OFF} = \lambda_{2ON}$. Thus, the influence from aerosol extinction and backscatter can be minimized by choosing appropriate pairs of wavelengths.

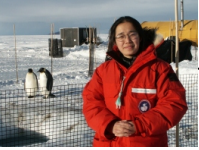

Solution for Dual-DIAL O_3

□ Ozone number density can be derived from above equations:

$$n_c(R) = \frac{1}{2\Delta\sigma_{abs}} \frac{d}{dR} \left\{ \begin{aligned} & \left[-\ln\left(\frac{P_S(\lambda_1^{ON}, R) - P_B}{P_S(\lambda_1^{OFF}, R) - P_B} \right) / \frac{P_S(\lambda_2^{ON}, R) - P_B}{P_S(\lambda_2^{OFF}, R) - P_B} \right] && \text{A} \\ & + \ln\left(\frac{P_L(\lambda_1^{ON})\eta(\lambda_1^{ON})}{P_L(\lambda_1^{OFF})\eta(\lambda_1^{OFF})} \right) / \frac{P_L(\lambda_2^{ON})\eta(\lambda_2^{ON})}{P_L(\lambda_2^{OFF})\eta(\lambda_2^{OFF})} \right] && \text{B} \\ & + \left[\ln\left(\frac{\beta_{aer}(\lambda_1^{ON}, R) + \beta_{mol}(\lambda_1^{ON}, R)}{\beta_{aer}(\lambda_1^{OFF}, R) + \beta_{mol}(\lambda_1^{OFF}, R)} \right) - \ln\left(\frac{\beta_{aer}(\lambda_2^{ON}, R) + \beta_{mol}(\lambda_2^{ON}, R)}{\beta_{aer}(\lambda_2^{OFF}, R) + \beta_{mol}(\lambda_2^{OFF}, R)} \right) \right] && \text{C} \end{aligned} \right\} \\
 - \frac{1}{\Delta\sigma_{abs}} \left\{ \begin{aligned} & \left[\left(\alpha_{aer}(\lambda_1^{ON}, R) - \alpha_{aer}(\lambda_1^{OFF}, R) \right) - \left(\alpha_{aer}(\lambda_2^{ON}, R) - \alpha_{aer}(\lambda_2^{OFF}, R) \right) \right] && \text{D} \\ & + \left[\left(\alpha_{mol}(\lambda_1^{ON}, R) - \alpha_{mol}(\lambda_1^{OFF}, R) \right) - \left(\alpha_{mol}(\lambda_2^{ON}, R) - \alpha_{mol}(\lambda_2^{OFF}, R) \right) \right] && \text{E} \\ & + \left[\left(\sigma_{IG}(\lambda_1^{ON}, R) - \sigma_{IG}(\lambda_1^{OFF}, R) \right) - \left(\sigma_{IG}(\lambda_2^{ON}, R) - \sigma_{IG}(\lambda_2^{OFF}, R) \right) \right] n_{IG}(R) && \text{F} \end{aligned} \right\}$$

Where the differential absorption cross-section is defined as

$$\Delta\sigma_{abs} = \left(\sigma_{abs}(\lambda_1^{ON}, r) - \sigma_{abs}(\lambda_1^{OFF}, r) \right) - \left(\sigma_{abs}(\lambda_2^{ON}, r) - \sigma_{abs}(\lambda_2^{OFF}, r) \right)$$

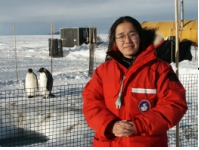

Choice of Wavelength for Dual-DIAL

$$\Delta\beta = \ln\left(\frac{\beta_{aer}(\lambda_1^{ON}, R) + \beta_{mol}(\lambda_1^{ON}, R)}{\beta_{aer}(\lambda_1^{OFF}, R) + \beta_{mol}(\lambda_1^{OFF}, R)}\right) - \ln\left(\frac{\beta_{aer}(\lambda_2^{ON}, R) + \beta_{mol}(\lambda_2^{ON}, R)}{\beta_{aer}(\lambda_2^{OFF}, R) + \beta_{mol}(\lambda_2^{OFF}, R)}\right)$$

$$\Delta\alpha_{aer} = \left(\alpha_{aer}(\lambda_1^{ON}, R) - \alpha_{aer}(\lambda_1^{OFF}, R)\right) - \left(\alpha_{aer}(\lambda_2^{ON}, R) - \alpha_{aer}(\lambda_2^{OFF}, R)\right)$$

$$\Delta\alpha_{mol} = \left(\alpha_{mol}(\lambda_1^{ON}, R) - \alpha_{mol}(\lambda_1^{OFF}, R)\right) - \left(\alpha_{mol}(\lambda_2^{ON}, R) - \alpha_{mol}(\lambda_2^{OFF}, R)\right)$$

$$\Delta\sigma_{IG} = \left(\sigma_{IG}(\lambda_1^{ON}, R) - \sigma_{IG}(\lambda_1^{OFF}, R)\right) - \left(\sigma_{IG}(\lambda_2^{ON}, R) - \sigma_{IG}(\lambda_2^{OFF}, R)\right)$$

$$\Delta\sigma_{abs} = \left(\sigma_{abs}(\lambda_1^{ON}, r) - \sigma_{abs}(\lambda_1^{OFF}, r)\right) - \left(\sigma_{abs}(\lambda_2^{ON}, r) - \sigma_{abs}(\lambda_2^{OFF}, r)\right)$$

❑ Different channels interact on the same aerosols and interference gases (IG) but with different wavelengths. The main error in conventional DIAL is caused by the uncertainty of the wavelength dependence and information (like density) of the backscatter, extinction, and interference owing to aerosols and IG.

$$\beta_{aer}(\lambda) \propto \frac{1}{\lambda^a}, \quad \alpha_{aer}(\lambda) \propto \frac{1}{\lambda^a}$$

❑ If the wavelength dependence (Angstrom factor) is stable within the detection wavelength range, it is possible to cancel the influence by carefully choosing the wavelengths of two pairs - the difference between two pairs can be minimized.



Solution for Dual-DIAL O_3

- ❑ By choosing the pairs of wavelengths, terms C-F (now the difference between two pairs of DIAL wavelengths) can be minimized or cancelled out. Thus, the O_3 measurement errors caused by the uncertainties of terms C-F can be dramatically decreased.
- ❑ Notice that the choice of the pairs of wavelengths must satisfy one important condition that the differential absorption cross-section given above must be large enough to meet the requirements of measurements sensitivity and spatial resolution.
- ❑ For the O_3 measurements, the dual-DIAL can be carried out by three wavelengths chosen at 277.1, 291.8, and 313.2 nm. The middle wavelength 291.8 nm acts as the off-wavelength for the 1st pair, while the on-wavelength for the 2nd pair.
- ❑ To minimize the influence from aerosol backscatter and extinction, a constant C can be introduced into above lidar equation. C is approximately determined by the ratio of the wavelength differences between two pairs of DIAL:

$$C = \frac{\lambda_1^{ON} - \lambda_1^{OFF}}{\lambda_2^{ON} - \lambda_2^{OFF}}$$

Here $\lambda_1^{OFF} = \lambda_2^{ON}$

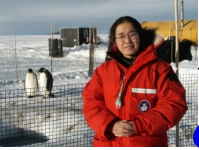

Solution with Constant C Introduced

$$n_c(R) = \frac{1}{2\Delta\sigma_{abs}} \frac{d}{dR} \left\{ \begin{array}{l} \text{--- A ---} \\ -\ln \left(\frac{P_S(\lambda_1^{ON}, R) - P_B}{P_S(\lambda_1^{OFF}, R) - P_B} \middle/ \left(\frac{P_S(\lambda_2^{ON}, R) - P_B}{P_S(\lambda_2^{OFF}, R) - P_B} \right)^C \right) \\ \text{--- B ---} \\ + \ln \left(\frac{P_L(\lambda_1^{ON})\eta(\lambda_1^{ON})}{P_L(\lambda_1^{OFF})\eta(\lambda_1^{OFF})} \middle/ \left(\frac{P_L(\lambda_2^{ON})\eta(\lambda_2^{ON})}{P_L(\lambda_2^{OFF})\eta(\lambda_2^{OFF})} \right)^C \right) \\ \text{--- C ---} \\ + \left[\ln \left(\frac{\beta_{aer}(\lambda_1^{ON}, R) + \beta_{mol}(\lambda_1^{ON}, R)}{\beta_{aer}(\lambda_1^{OFF}, R) + \beta_{mol}(\lambda_1^{OFF}, R)} \right) - C \ln \left(\frac{\beta_{aer}(\lambda_2^{ON}, R) + \beta_{mol}(\lambda_2^{ON}, R)}{\beta_{aer}(\lambda_2^{OFF}, R) + \beta_{mol}(\lambda_2^{OFF}, R)} \right) \right] \end{array} \right\} \\
 - \frac{1}{\Delta\sigma_{abs}} \left\{ \begin{array}{l} \text{--- D ---} \\ \left[\left(\alpha_{aer}(\lambda_1^{ON}, R) - \alpha_{aer}(\lambda_1^{OFF}, R) \right) - C \left(\alpha_{aer}(\lambda_2^{ON}, R) - \alpha_{aer}(\lambda_2^{OFF}, R) \right) \right] \\ \text{--- E ---} \\ + \left[\left(\alpha_{mol}(\lambda_1^{ON}, R) - \alpha_{mol}(\lambda_1^{OFF}, R) \right) - C \left(\alpha_{mol}(\lambda_2^{ON}, R) - \alpha_{mol}(\lambda_2^{OFF}, R) \right) \right] \\ \text{--- F ---} \\ + \left[\left(\sigma_{IG}(\lambda_1^{ON}, R) - \sigma_{IG}(\lambda_1^{OFF}, R) \right) - C \left(\sigma_{IG}(\lambda_2^{ON}, R) - \sigma_{IG}(\lambda_2^{OFF}, R) \right) \right] n_{IG}(R) \end{array} \right\}$$

Where the differential absorption cross-section is defined as

$$\Delta\sigma_{abs} = \left(\sigma_{abs}(\lambda_1^{ON}, r) - \sigma_{abs}(\lambda_1^{OFF}, r) \right) - C \left(\sigma_{abs}(\lambda_2^{ON}, r) - \sigma_{abs}(\lambda_2^{OFF}, r) \right)$$

Simulation Results for Dual-DIAL O₃

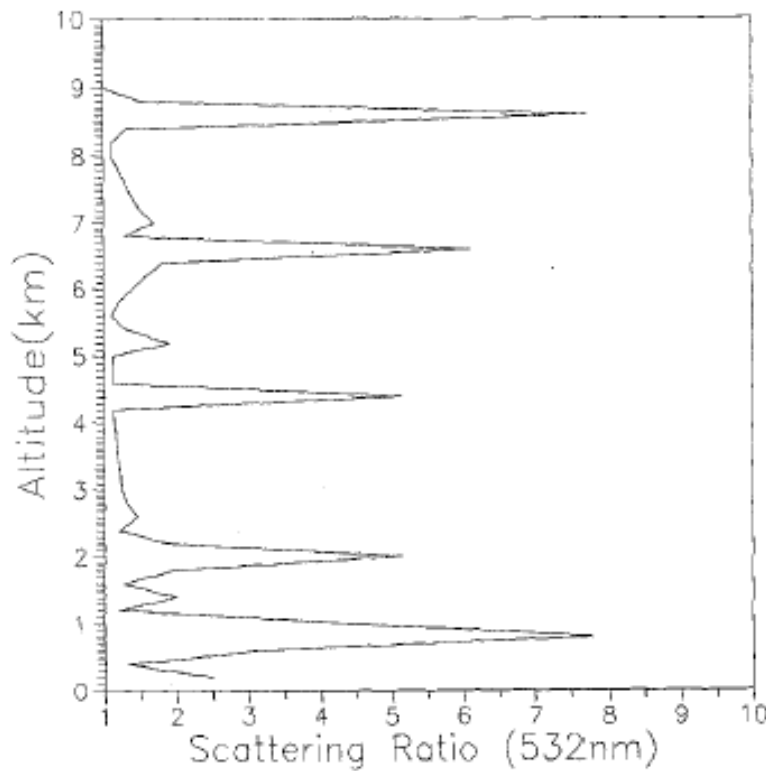

Fig. 1. Profile of the aerosol scattering ratio (532 nm)

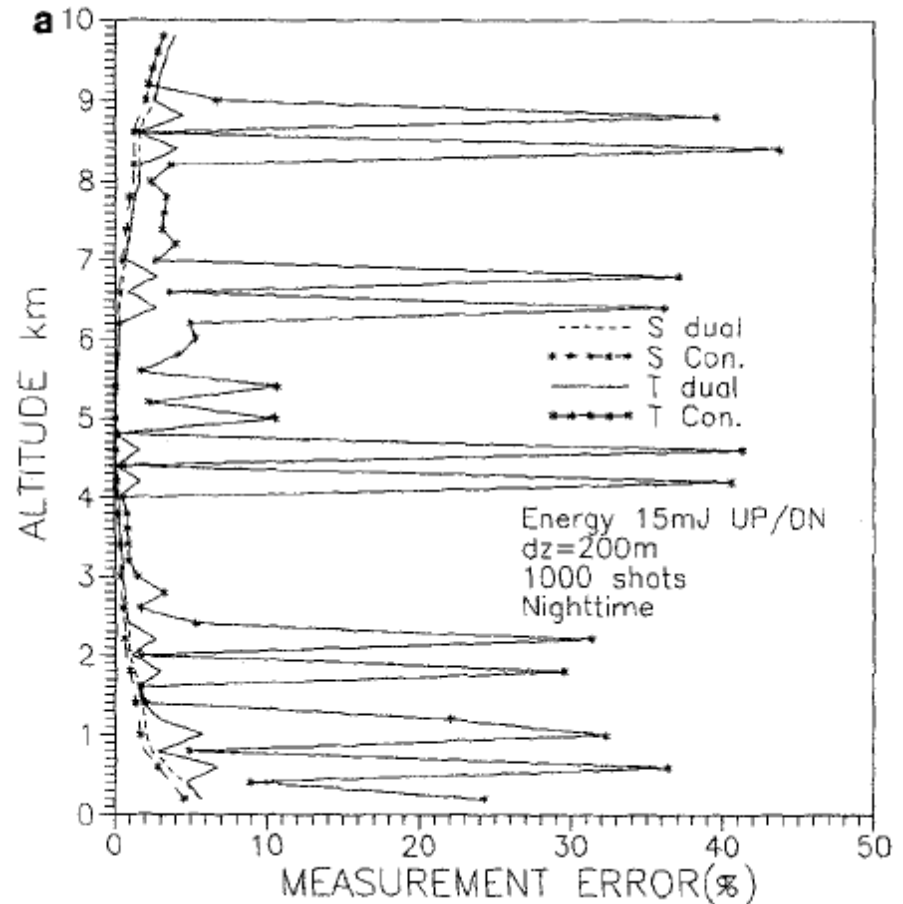
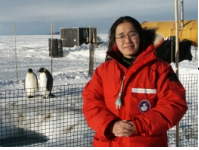

Fig. 2a, b. Simulations of measurement error vs altitude for the dual-DIAL with 277.1, 291.8, 313.2 nm and conventional DIAL with 277.1, 291.8 nm operated from an aircraft flying at an altitude of 5 km. The ozone profile is the US standard ozone profile. In the legend, *S* represents the statistical error, *T* the total measurement error, *dual* the dual-DIAL method and *con.* the conventional DIAL method: (a) night-time; (b) day-time

$$C = 0.65$$



Dual-DIAL for SO₂ Measurements

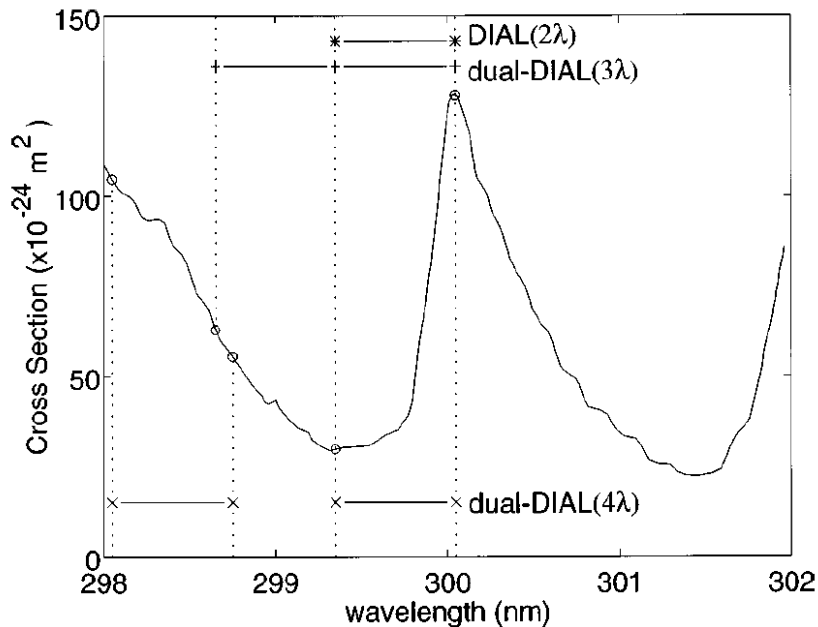

Fig. 1 Absorption cross section of SO₂. The wavelengths used in two-wavelength DIAL, three-wavelength dual-DIAL, and four-wavelength dual-DIAL are indicated.

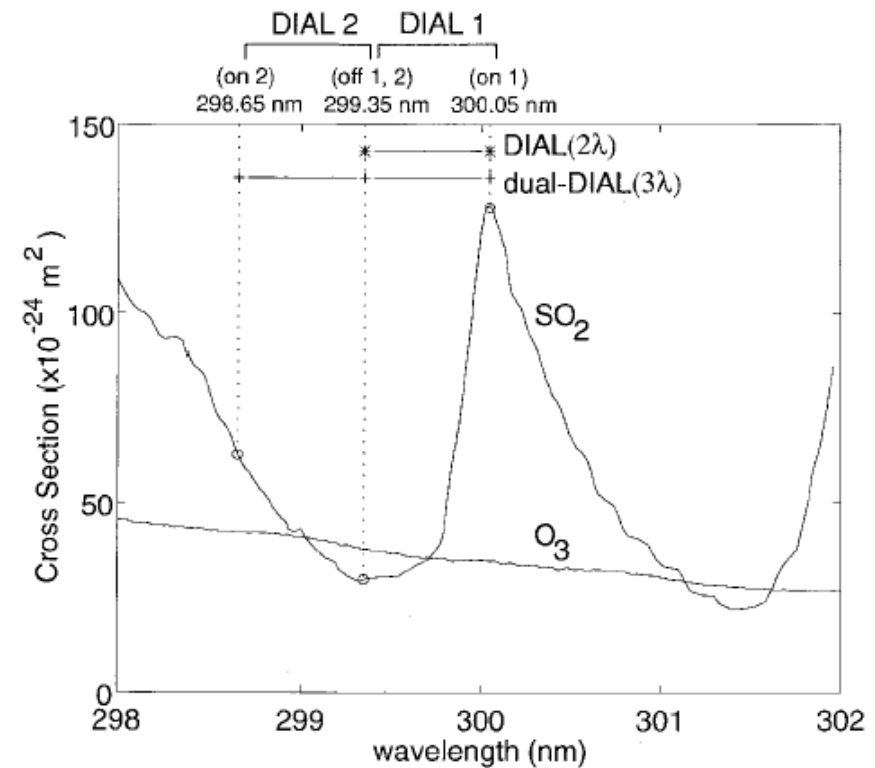
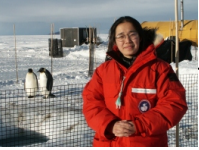

Fig. 1. Wavelengths used in three-wavelength dual DIAL for SO₂, and absorption cross sections of SO₂ and O₃.

Fukuchi et al., Opt. Eng., 38, 141-145, 1999
 Fujii et al., Applied Optics, 40, 949-956, 2001



Dual-DIAL for SO₂ Measurements

Table 1 Cases considered for SO₂ measurement. $n\sigma'$ and $n\sigma''$ are given for a SO₂ concentration of 1 ppb.

Method	σ'_0, σ''_0 (10^{-24} m ²)	$n\sigma'_0, n\sigma''_0$ (10^{-6} m ⁻¹)	α'_x, α''_x (10^{-6} m ⁻¹)	i	λ_i (nm)	e_i	
DIAL	98.0	2.5	-3.7	1	299.35	-1 ^a	
				2	300.05	+1 ^b	
Dual-DIAL:							
3-wavelength	131	3.3	0.83	1	298.65	+1	
				2	299.35	-1	
				3			
				4			300.05
4-wavelength	148	3.8	0.094	1	298.05	+1	
				2	298.75	-1	
				3			299.35
				4			300.05

^aOff.

^bOn.

$$n = \frac{1}{2 \Delta R \sigma''_0} \left[\sum_{i=1}^m e_i Z(R, \lambda_i) - \sum_{i=1}^m e_i B(R, \lambda_i) \right] - \frac{\alpha''_x}{\sigma''_0}$$

$$\sigma''_0 = \sum_{i=1}^m e_i \sigma_0(\lambda_i)$$

$$\alpha''_x = \sum_{i=1}^m e_i \alpha_x(\lambda_i) \quad (29)$$

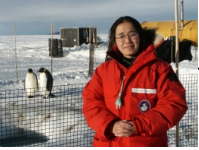

Comparison of Constituent Lidar Tech

Technique	Signal Source & Trace Gas		Interests
Resonance Fluorescence Lidar	Resonance fluorescence from metal atoms in the middle and upper atmosphere (70-200 km)		Temp, Wind, Density, Wave
Resonance Fluorescence Lidar	Resonance fluorescence from He, N ₂ ⁺ , O in thermosphere		Density, Temp Wind, etc
Conventional DIAL	Elastic-scattering from air molecules and aerosols	Trace gas absorption in the extinction terms	Species, Density
Raman Lidar	Inelastic Raman scattering from trace gas and reference N ₂ or O ₂ (no aerosol scattering)	Trace gas scattering in the backscatter terms, Trace gas absorption in the extinction terms	Species, Density, Mixing ratio
Raman DIAL	Inelastic Raman scattering from N ₂ or O ₂	Trace gas absorption in the extinction terms	Species, Density
RVR Raman DIAL	Pure rotational Raman scattering from N ₂ and O ₂ and Vibrational-Rotational Raman scattering from N ₂ or O ₂	Trace gas absorption in the extinction terms	Species, Density
Multiwavelength (Raman) DIAL	Elastic scattering from air molecules and aerosols	Trace gas absorption in the extinction terms	Species, Density

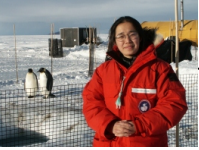

Backscatter Cross-Section Comparison

Physical Process	Backscatter Cross-Section	Mechanism
Mie (Aerosol) Scattering	$10^{-8} - 10^{-10} \text{ cm}^2\text{sr}^{-1}$	Two-photon process Elastic scattering, instantaneous
Atomic Absorption and Resonance Fluorescence	$10^{-13} \text{ cm}^2\text{sr}^{-1}$	Two single-photon process (absorption and spontaneous emission) Delayed (radiative lifetime)
Molecular Absorption	$10^{-19} \text{ cm}^2\text{sr}^{-1}$	Single-photon process
Fluorescence From Molecule, Liquid, Solid	$10^{-19} \text{ cm}^2\text{sr}^{-1}$	Two single-photon process Inelastic scattering, delayed (lifetime)
Rayleigh Scattering (Wavelength Dependent)	$10^{-27} \text{ cm}^2\text{sr}^{-1}$	Two-photon process Elastic scattering, instantaneous
Raman Scattering (Wavelength Dependent)	$10^{-30} \text{ cm}^2\text{sr}^{-1}$	Two-photon process Inelastic scattering, instantaneous

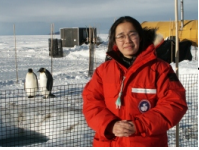

Summary for Constituent Lidars

- ❑ To identify species and to measure species, spectroscopy is the key for constituent lidars to infer spectral information of the species. These lidars use atomic resonance fluorescence, molecular absorption, or Raman scattering or combination of differential absorption with Raman scattering to obtain the specie spectrum. The key is to gain spectral information as much as possible, with multiple frequencies or multiple wavelengths.
- ❑ Lower atmosphere study poses a great challenge to lidar community, as many factors (especially the aerosol backscatter and extinction) are involved with each other and make the derivation of precise information on trace gases a very complicated procedure.
- ❑ Different techniques have been developed or proposed for solving these problems. The main idea is how to minimize the influence from aerosol backscatter and extinction and how to minimize the interference from other gas molecules.



Summary for Constituent Lidars

- ❑ The essential point for Raman lidar is to avoid the aerosol scattering in the Raman-shifted channel. Thus, only aerosol extinction will be dealt with in deriving constituent density. Aerosol extinction can be safely estimated by introducing Angstrom exponent. The error introduced by Angstrom uncertainty is much less than the lidar ratio or backscatter coefficient.
- ❑ Combination of Raman and DIAL can effectively remove the influence from aerosol or interference gases.
- ❑ More combination and approaches using DIAL and Raman are on the way to solve practical constituent detection problems.
- ❑ Again, spectroscopy is the key to guide the laser wavelength selection and DIAL/Raman considerations.



Summary for Constituent Lidars

- ❑ Two major solutions for now: to use Raman scattering to avoid aerosol scattering get into the signal channels, or to use multi-wavelength selection to cancel out the influence from aerosol and other molecules.
- ❑ Other possible ways are to measure several interference gases simultaneously with multiple channels or to combine the DIAL with Doppler lidar etc to study the dynamic transportation of pollutant.
- ❑ The DIAL and Raman lidars are still far from perfection. It could be a growing point in lidar field.
- ❑ The resonance fluorescence lidar for thermosphere species is still under development. The main point is to develop the proper laser transmitter that can give the right wavelength and high enough power. As O resonance frequency is in the far UV range (131 nm), the O lidar has to be operated from the space down-looking to avoid the UV absorption by ozone and atmospheric molecules.