



Lecture 31. Lidar Design Considerations

- ❑ Introduction
- ❑ Lidar Architecture: Configurations & Arrangements
- ❑ Lidar Design: Basic Ideas and Basic Principles
- ❑ Considerations on Various Aspects of Lidar Design
- ❑ An Example of Lidar Design and Development
- ❑ Lidar Calibration
- ❑ Summary



Introduction

❑ Lidar design is to design a lidar system that meets our measurement goals. Lidar design is based on our understanding of the physical interactions and processes involved and utilizes the lidar simulations to assess the lidar performances, errors, and sensitivities.

❑ Lidar design includes

- (1) Choice of what type of lidar to use, based on measurement objectives (subject), measurement requirements (accuracy, precision, and resolution) and operation requirements (reliability, stability, operation difficulty), considering physical interactions and processes involved (how well we know the details), potential signal levels, and available hardware, etc.
- (2) Choice of what kind of wavelength, bandwidth, and diurnal coverage to use, based on potential return SNR, available hardware, etc.
- (3) Choice of what kind of laser, frequency control, receiver, filter, detector, DAQ to use, based on measurement requirements, available hardware, etc.
- (4) Design the lidar system based on above choices, and run simulations or basic tests or prototypes to predict the lidar performance.



LIDAR Architecture

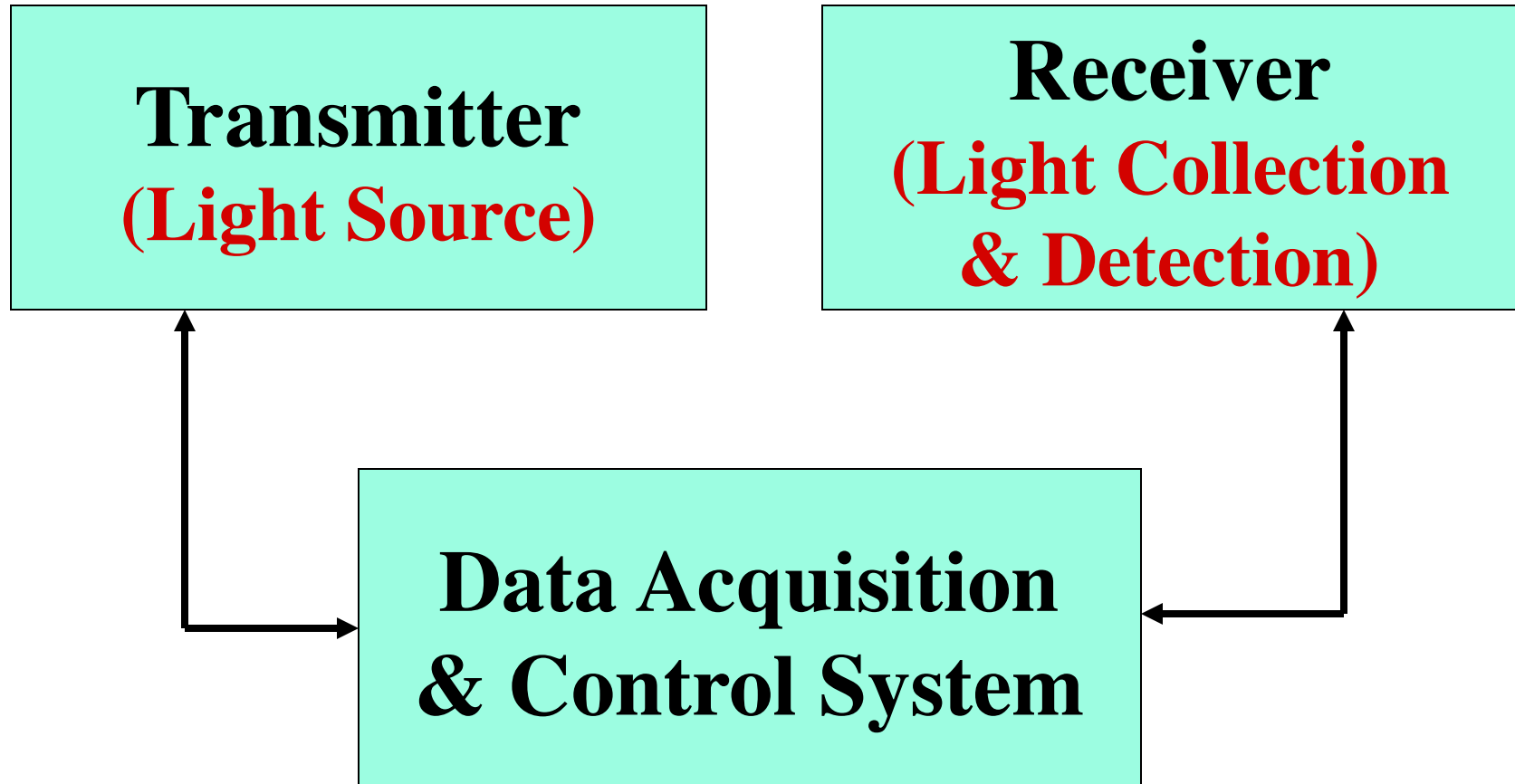

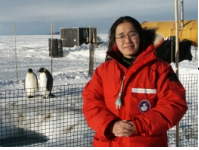

STAR Lidar Design

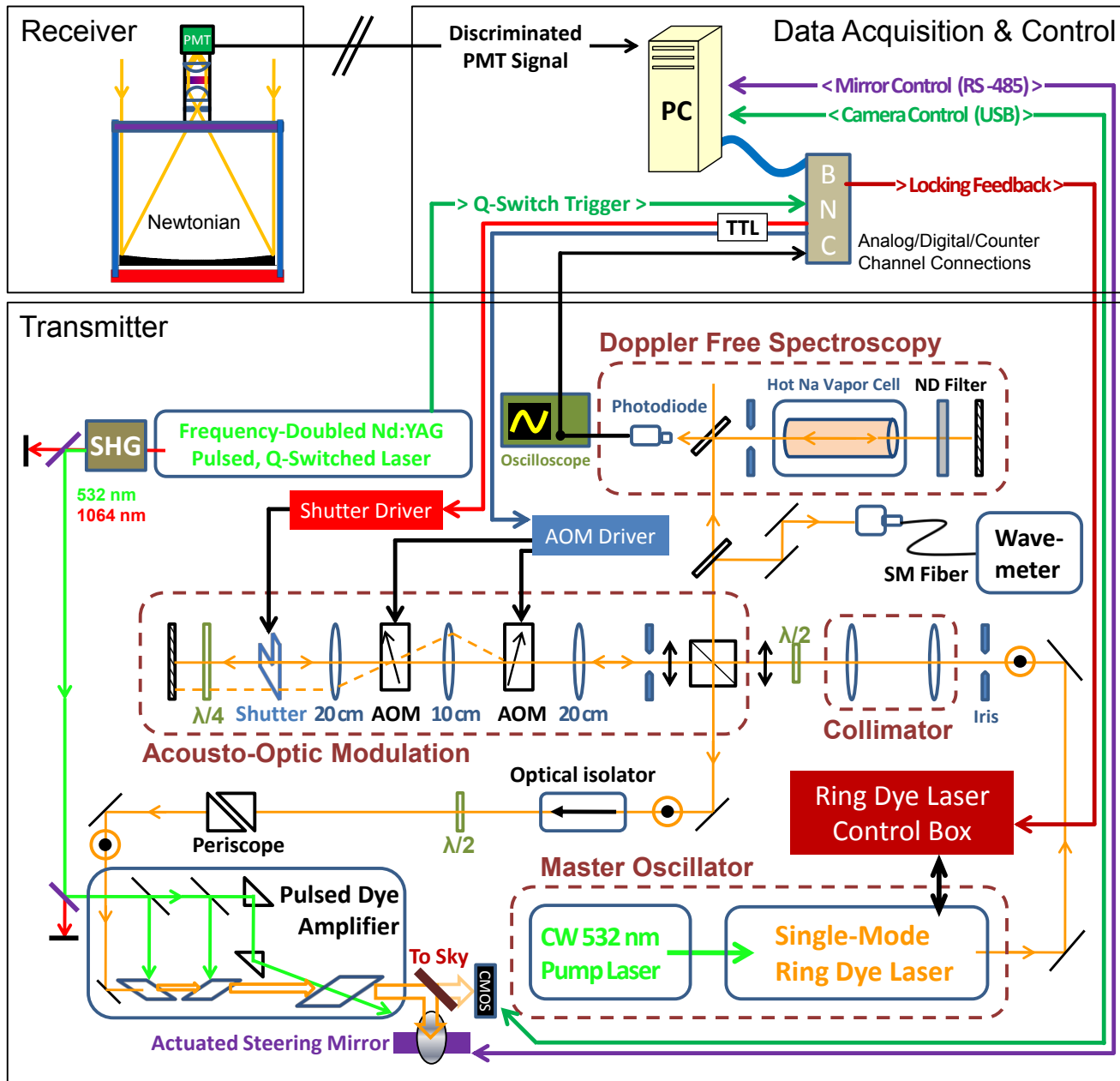

Based on ILRC paper by Smith et al. [2012]

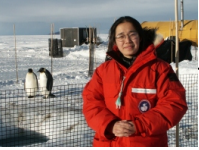

Novel Architecture of LIDAR

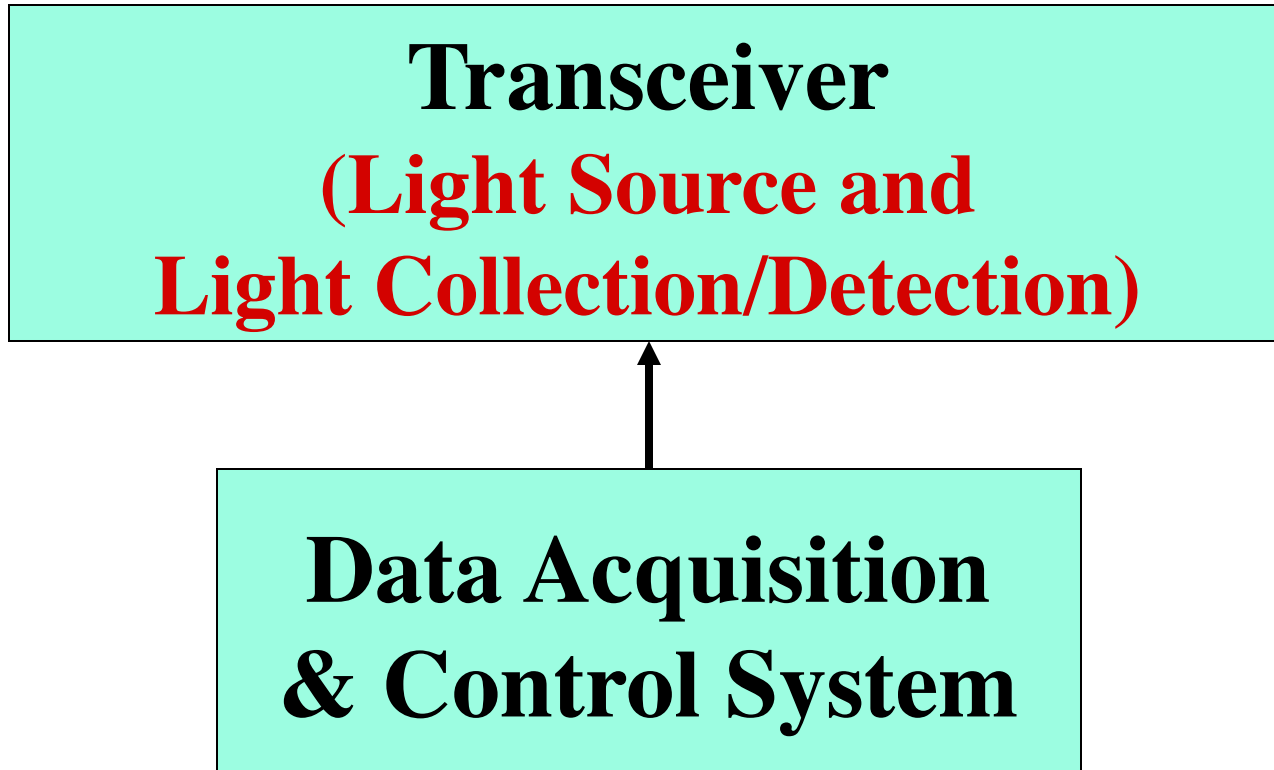

- ❑ Transceiver is becoming more and more popular for compact lidars in mobile systems, like ground-based mobile lidars or airborne and spaceborne lidars for the lower atmosphere detection.

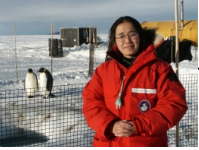

Lidar with Holographic Optical Element

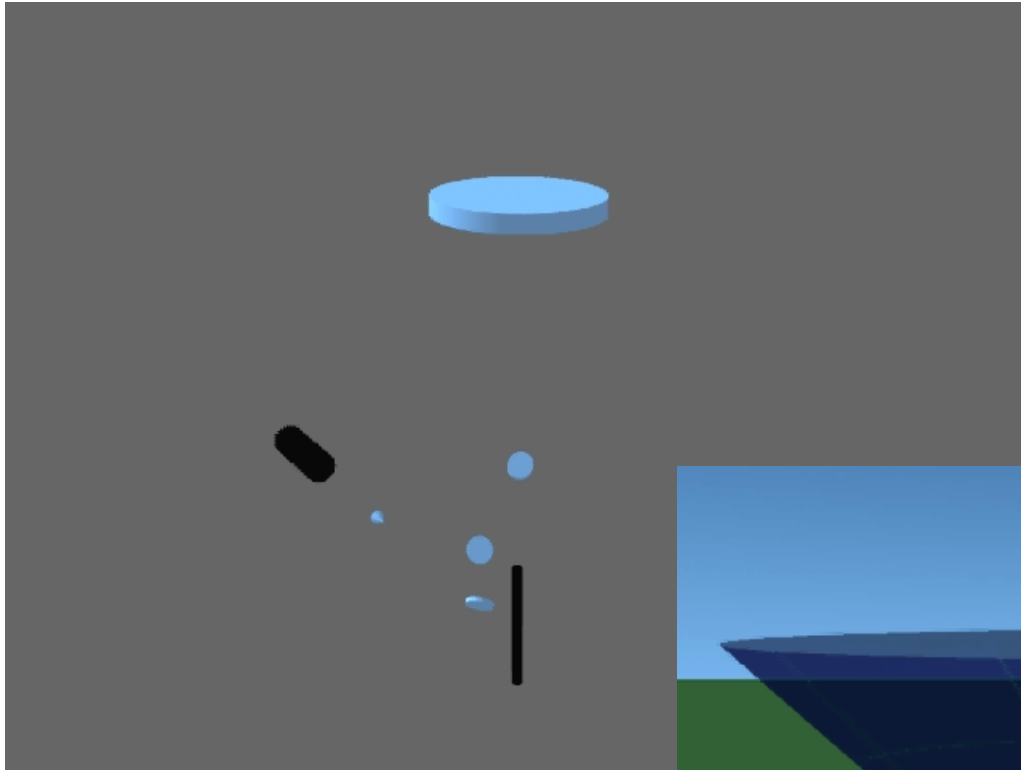

Courtesy of
Geary Schwemmer

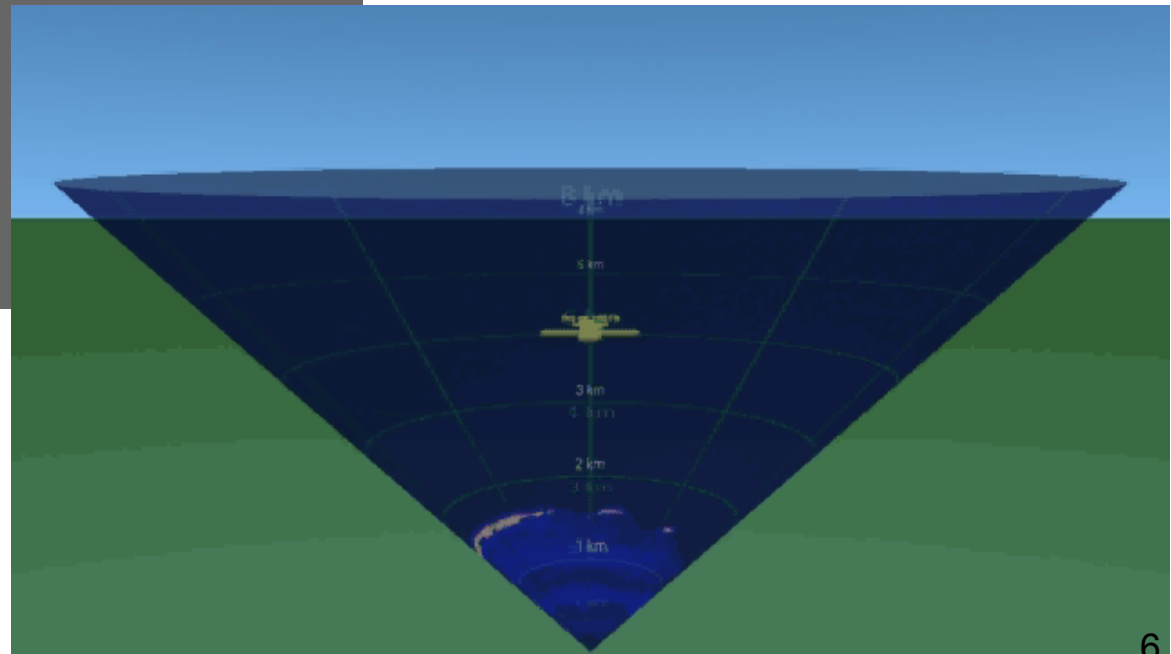

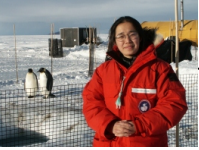

LIDAR Arrangements: Biaxial and Coaxial

- ❑ There are considerable amount of lidars using biaxial arrangements although they have monostatic configurations.
- ❑ In the biaxial arrangement, the laser beam and the receiver axis are separated, and the laser beam only enters the field of view of the receiver optics beyond some predetermined range.
- ❑ Biaxial arrangement helps avoiding near-field backscattered radiation that may saturate photo-detector.
- ❑ In the coaxial arrangement, the axis of the laser beam is coincident with the axis of the receiver optics.
- ❑ Therefore, the receiver can see the laser beam since the zero range bin. (There are debates on this point – depending on the telescope structure!)
- ❑ The near-field backscattering problem in a coaxial system can be overcome by either gating of the photo-detector or use of a fast shutter or chopper to block the near-field scattering.

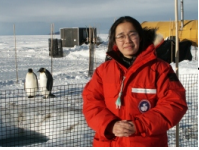

Basic Ideas of Lidar Design

- ❑ The key of lidar design is the understanding of physical interactions and processes involved, the lidar simulations, and the choices of lidar type, configuration, arrangement, hardware and software to meet the measurement goals (subject, accuracy, precision, resolution, coverage).
- ❑ The basic procedure of lidar design includes
 - (1) Study of physical interactions, processes, and spectroscopy for their applications in the lidar field. Study of lidar principles and technologies.
 - (2) Choice of what type of lidar to use, based on measurement objectives and requirements (subject, accuracy, precision, resolution, reliability, stability, operation difficulty, etc).
 - (3) Choice of what kind of wavelength, bandwidth, and diurnal coverage to use, based on potential return SNR, available hardware, etc.
 - (4) Choice of what kind of laser, frequency control, receiver, detector, filter, and DAQ to use, based on measurement requirements, available hardware, etc.
 - (5) Design the lidar system based on above choices, and run simulations or basic tests or prototypes to predict the lidar performance.



Considerations on Lidar Design

- What type of lidar: Mie, Rayleigh, Raman, resonance fluorescence, DIAL, coherent, direction-detection Doppler, fluorescence, rangefinder, altimeter, HSRL?
- Bistatic or monostatic?
- Biaxial or coaxial?
- Geometrical overlap
- Uplooking or downlooking?
- Care about only scattering or only timing or both?
- Wavelength for transmitter and receiver
- Tunable or not?
- Bandwidth for transmitter and receiver
- Frequency stability for transmitter and receiver
- Power/energy consideration (especially in space-, balloon- or UAV-borne)
- Nighttime or full diurnal capability?
- Mobile or not?
- Volume, mass, cost, reliability, robustness, operation, etc?



Further Considerations

- Doppler shift and how much?
- Polarization detection or not?
- Pulse repetition rate
- Beam divergence
- Layer saturation (to Fe, Na, K, etc. layers or other atoms/molecules)
- Photo detector dynamic range
- Bin width and resolution
- Record every pulse or not?
- Record system parameters or not?
- Timing control (how accurate and how precise it must be?)
- Need precise beam point control or not?
- Need real time data reduction or not?
- Eye safe or not?
-



Choice of Lidar Types

- To choose the right type, we have to know how many types of lidars are available and the capabilities and limitations/issues of each type of lidar. This is why we have to go through all types of lidars in our class to give you a comprehensive overview.
- The choice of lidar type is mainly driven by the measurement goals, available expertise, and available hardware.
- Conventional Mie and Rayleigh lidar
- Pure Rotational Raman lidar
- Vibrational-Rotational Raman lidar
- Differential absorption lidar
- Broadband resonance fluorescence lidar
- Narrowband resonance-fluorescence Doppler lidar
- Coherent Doppler lidar
- Direct-detection Doppler lidar
- High-spectral-resolution lidar
- Fluorescence lidar
- Laser range-finder and laser altimeter

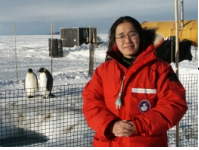

Capabilities and Limitations

- ❑ Conventional Mie/Rayleigh lidar: aerosol/cloud occurrence, geometry, size, shape (with polarization and multi-wavelength detection), density; atmospheric density and temperature (with Rayleigh integration technique) in aerosol-free region, ...
- ❑ Pure-Rotational Raman lidar: temperature in lower atmosphere, aerosols, species
- ❑ Vibrational-Rotational Raman lidar: temperature in lower atmosphere when aerosols present, species, ...
- ❑ Differential absorption lidar: various species in lower atmosphere, temperature
- ❑ Broadband resonance fluorescence lidar: various species and/or temperature in MLT (Boltzmann), Rayleigh temperature above 30 km, aerosols/clouds
- ❑ Narrowband resonance-fluorescence Doppler lidar: various species, temperature and wind in MLT, Rayleigh temp (& wind) above 30 km, aerosol/cloud of 10-100 km
- ❑ Coherent Doppler lidar: high-resolution wind in lower atmosphere
- ❑ Direct-detection Doppler lidar: wind and/or temperature in lower & middle atmos
- ❑ High-spectral-resolution lidar: aerosol optical properties, wind, or temp
- ❑ Fluorescence lidar: species in liquid or solid states
- ❑ Laser range-finder and laser altimeter: range and altitude determination

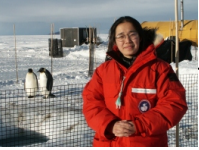

Configuration, Arrangement, Direction

- ❑ Most modern lidars (consisting of pulsed lasers) use monostatic configuration with either biaxial or coaxial arrangement. Lidars consisting of cw laser transmitters usually take bistatic configuration, in order to distinguish range, if coding technique is not applied.
- ❑ The choice of biaxial or coaxial arrangement is usually determined by the detection range. If near-field range is desired, coaxial arrangement is preferred as it provides full overlap of receiver field-of-view with laser beam. If near-field range is not desired, biaxial arrangement may help prevent the saturation of photo-detector by strong near-field scattering. Scanning capability can also come into play for the selection of biaxial or coaxial.
- ❑ Groundbased lidars are usually uplooking, while spaceborne lidars are usually downlooking. Airborne lidars can be either uplooking or downlooking, depending on application needs.
- ❑ The reason to care about up- or down-looking is the fact that atmospheric density decreases with altitude nearly exponentially. So the signal strength for up- or down-looking lidars will be quite different.

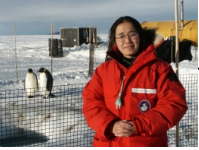

Wavelength Considerations

- ❑ Many factors determine the wavelength selection:
 - **First**, the detection subject – whether a specific wavelength is required, e.g., Na or Fe atomic transition wavelength, or H₂O differential absorption wavelength.
 - **Second**, signal-to-noise ratio considerations: Rayleigh (λ^{-4}), Mie (λ^{-2} to λ): e.g., Coherent lidar (Mie vs Rayleigh); VR Raman lidar (N₂ vs. O₂)
 - **Third**, transmission of laser light through the medium (e.g., atmosphere or water).
 - **Fourth**, the solar background intensity – low solar radiation is desirable to benefit signal-to-noise ratio (SNR) in daytime. Usually UV solar radiation is lower than visible and IR. Fraunhofer lines may be utilized.
 - **Fifth**, available hardware (wavelength vs. power/energy) is often to be a major limitation. Lasers, photo detectors, optics, opto-electronics, etc.
 - Another important factor in determining wavelength is eye-safety. UV and far IR are safer for people because our eyes cannot focus the light with wavelengths in these regions. Our eyes have much higher damage threshold in these wavelengths than visible light or near IR.

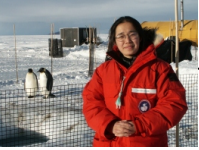

Fraunhofer Lines

- ❑ Fraunhofer lines are named after the German physicist [Joseph von Fraunhofer \(1787-1826\)](#). **Fraunhofer lines** in solar radiation are a set of several hundreds of dark lines appearing against the bright background of the continuous solar spectrum. They are produced via the absorption of light by the cooler gases in the Sun's outer atmosphere at frequencies corresponding to the atomic transition frequencies of these gases, such as atomic H, Fe, Na, K, Ca, Mg, Li, etc, or by oxygen of the Earth's atmosphere.
- ❑ Lidar operating at the wavelengths in deep Fraunhofer lines benefits from the lower solar background for daytime operations.

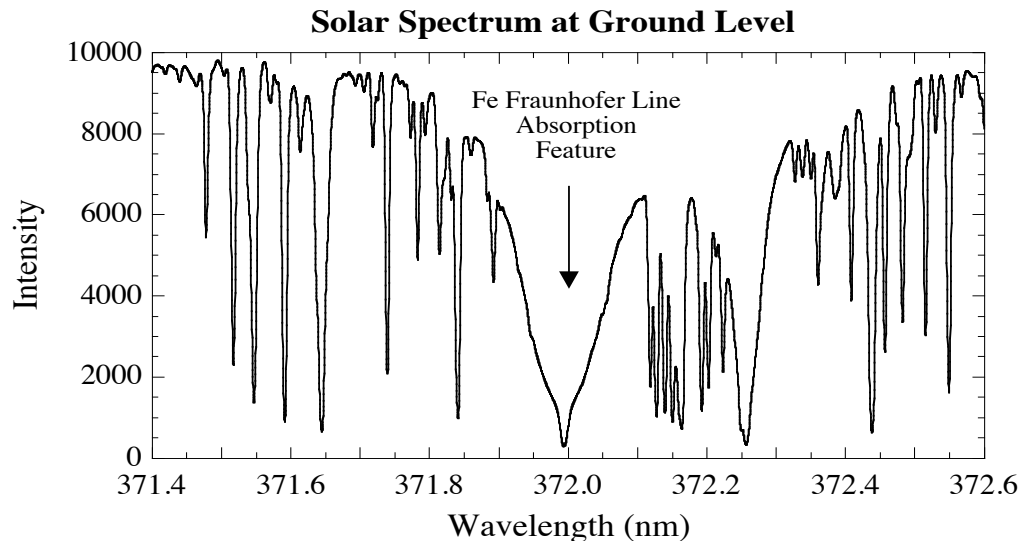

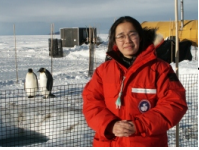

Bandwidth Considerations

- ❑ Possible combinations of transmitter and receiver

Broadband
Transmitter

+

Broadband
Receiver

Conventional Mie, Rayleigh,
Raman Scatter lidar, Broadband
Resonance Fluorescence lidar,
Differential Absorption lidar

Narrowband
Transmitter

+

Broadband
Receiver

Narrowband Resonance
Fluorescence Doppler lidar,
Differential Absorption lidar

Narrowband
Transmitter

+

Narrowband
Receiver

Coherent Doppler lidar,
Direct-Detection Wind lidar,
Rayleigh Doppler lidar.
High-Spectral-Resolution lidar

Broadband
Transmitter

+

Narrowband
Receiver

Potential broadband resonance
fluorescence temperature lidar,
Potential Rayleigh and Raman
temperature lidar



Nighttime-Only & Full Diurnal

- ❑ This is mainly a consideration on background suppression to ensure sufficient signal-to-noise ratio (SNR).
- ❑ Even for nighttime-only operation, interference filters are necessary to suppress background (like moon or star or city light) and ensure safe operation of photo detectors.
- ❑ Daytime operation needs extra suppression on much stronger solar background. Usually extra spectral filters with very narrow bandwidth are needed. Two major narrowband spectral filters: F-P etalons and atomic/molecular spectral filters (like Faraday filter or iodine filter).
- ❑ Spatial filter or minimized field-of-view (FOV) is also very necessary to largely suppress the solar background. Of course, this may be limited by layer saturation, geometrical overlap and alignment issues.
- ❑ FOV usually should be larger than the laser beam divergence to ensure that the receive sees the full lidar beam. When a tight FOV is used, active alignment/stabilization (beam steering) system may be necessary to ensure the FOV contains the full beam at all times.



Transmitter & Receiver

- ❑ Depending on application needs and lidar types, there may be several possible combinations of transmitter and receiver to satisfy the same goal. Choose the best one depending on science need, technical feasibility, cost, performance, reliability, etc.
- ❑ To choose tunable lasers or not depends on the application needs, e.g., resonance fluorescence and DIAL lidars usually need to be tunable, while conventional Mie, Rayleigh, and Raman scattering lidars can use fixed wavelengths.
- ❑ Selection of pulse energy, repetition rate, and duration time, mainly concerns the SNR, measurement resolution, as well as cost, volume, mass, etc. to the entire system.
- ❑ Selection of telescope area, type, configuration; detector type, size, quantum efficiency, maximum count rate; filter type, size, bandwidth, transmission, mainly concerns the SNR, measurement resolution, as well as cost, volume, mass, etc. to the entire system.

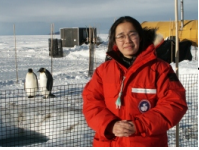

Major Research Instrumentation (MRI)

Fe/Rayleigh/Mie Doppler Lidar

Why choosing Fe Doppler lidar?

- High product of abundance, cross-section, power and aperture for the best measurements of temperature and wind (high SNR)
- Large measurement range (30 to 155 km) considering strong Rayleigh scattering
- Interesting science questions on Fe chemistry and dynamics

Pulsed Alexandrite Ring Laser (PARL) and frequency control

- Tunable and solid-state laser for mobile
- Bias-free and single pulse frequency control

Wavelength selection (372 nm)

- Larger (>2) effective cross-section

Narrowband laser + broadband receiver

leading to the best accuracy and precision

3-frequency tech. for the highest resolution

Choice of receiver, filter, DAQ: Newtonian telescopes for low cost

Platform: Lidar containers for mobile deployment

Potential expansion in the future: Candidate for Whole Atmosphere Lidar

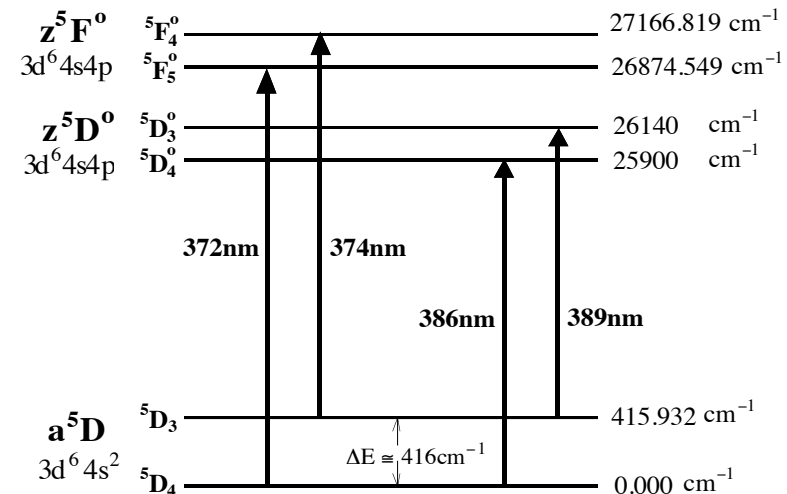

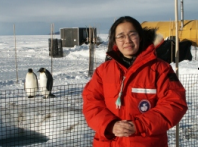

MRI Fe Doppler Lidar Design

[Chu et al., ILRC, 2010]

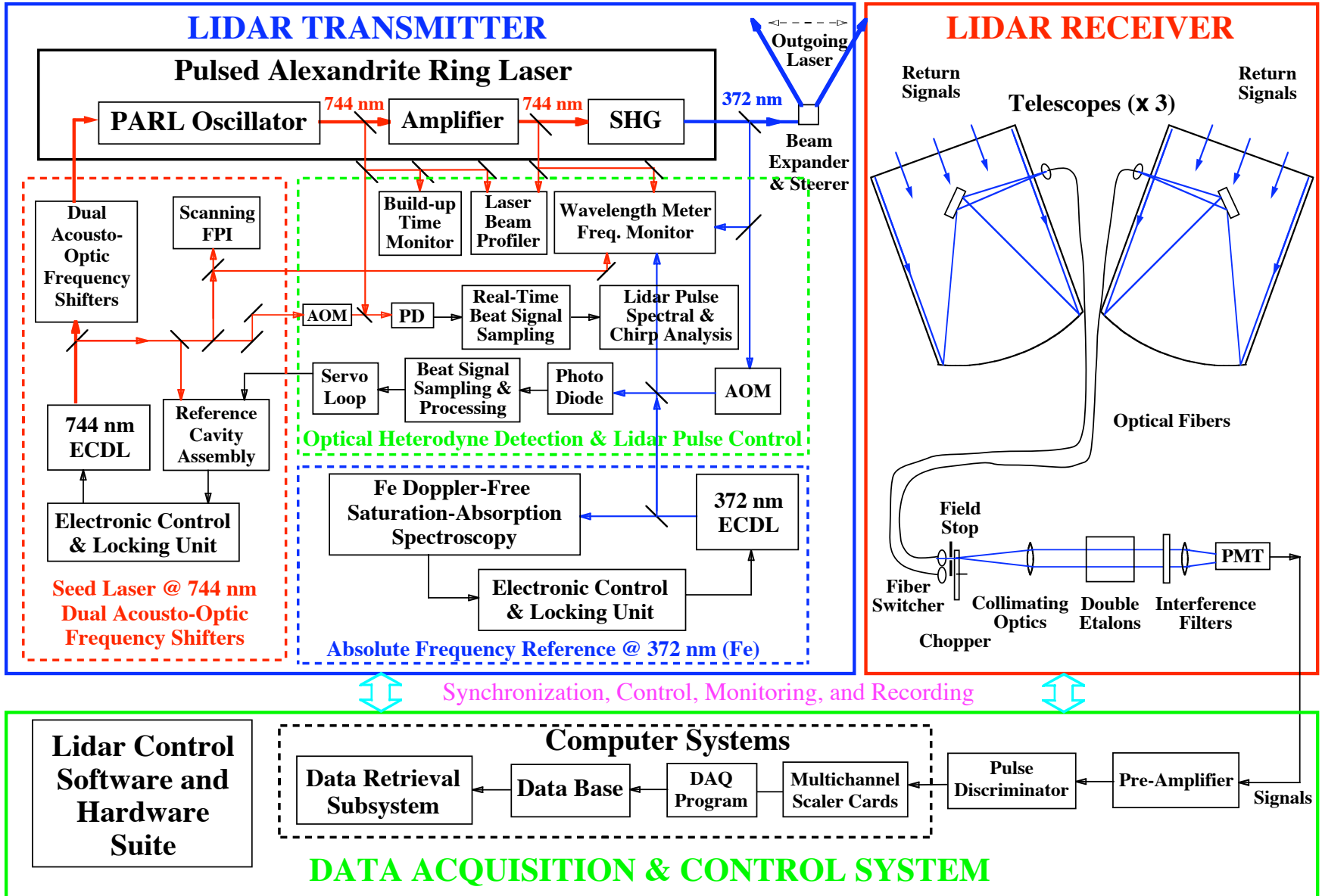

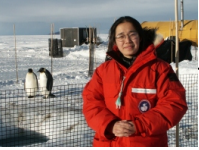

Lidar Simulations

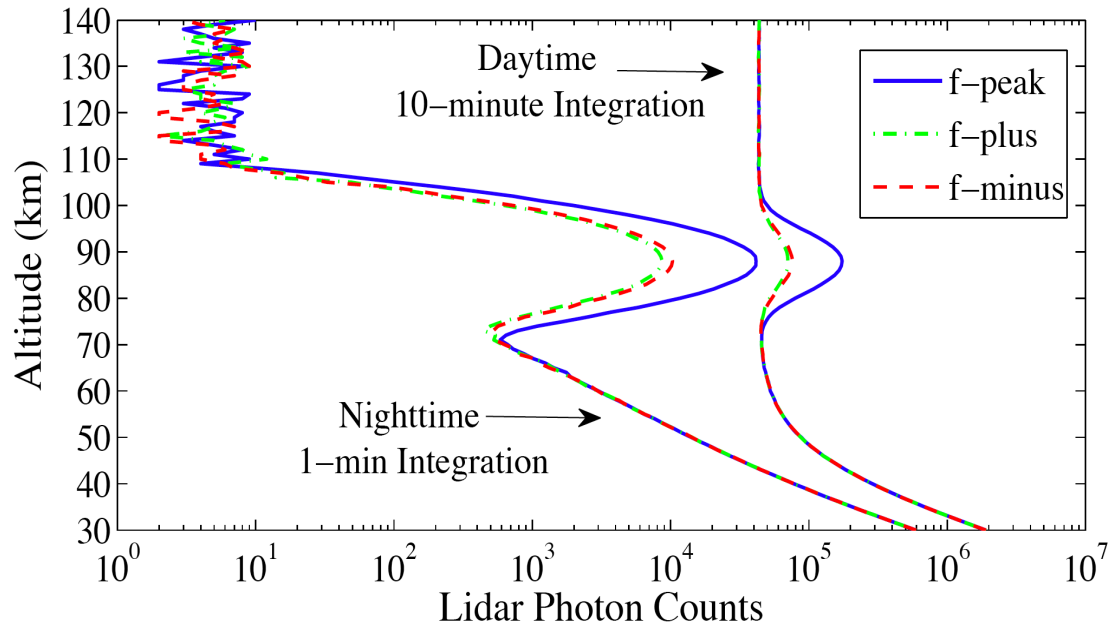

Simulated MRI lidar photon count returns for both day and night measurements and simulated MRI Doppler lidar measurements of temperature and wind for 1-km resolution and 1-min integration at an off-zenith angle of 35° in nighttime configuration. The errors are less than 1 K and 1 m/s at the Fe layer peak. Comparable features can be achieved with 10-min integration in daytime conditions.

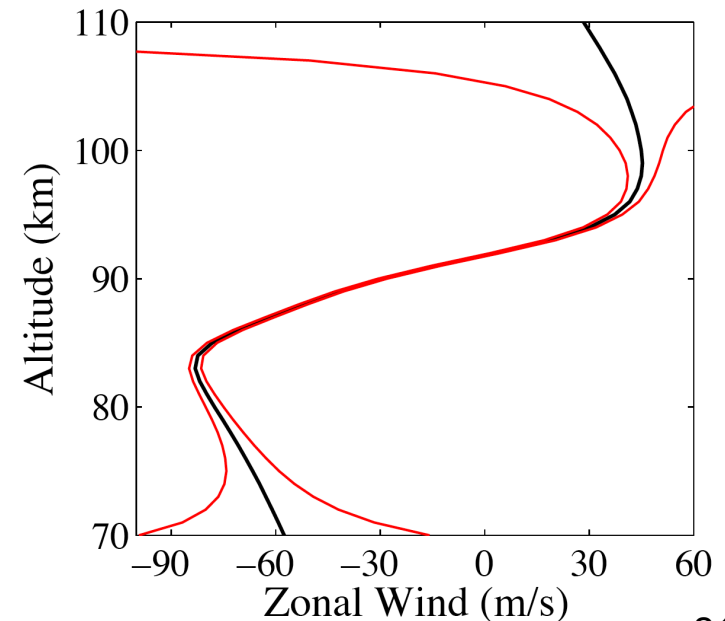
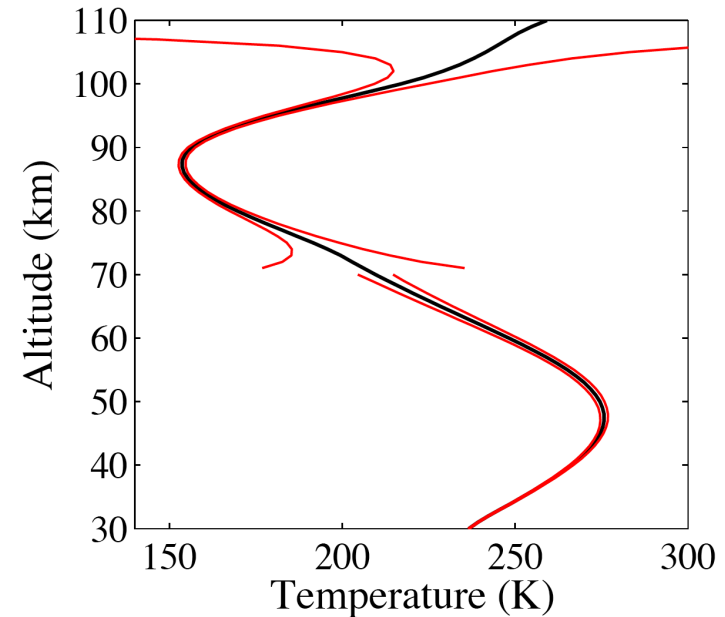



MRI Fe Doppler LIDAR - First Light

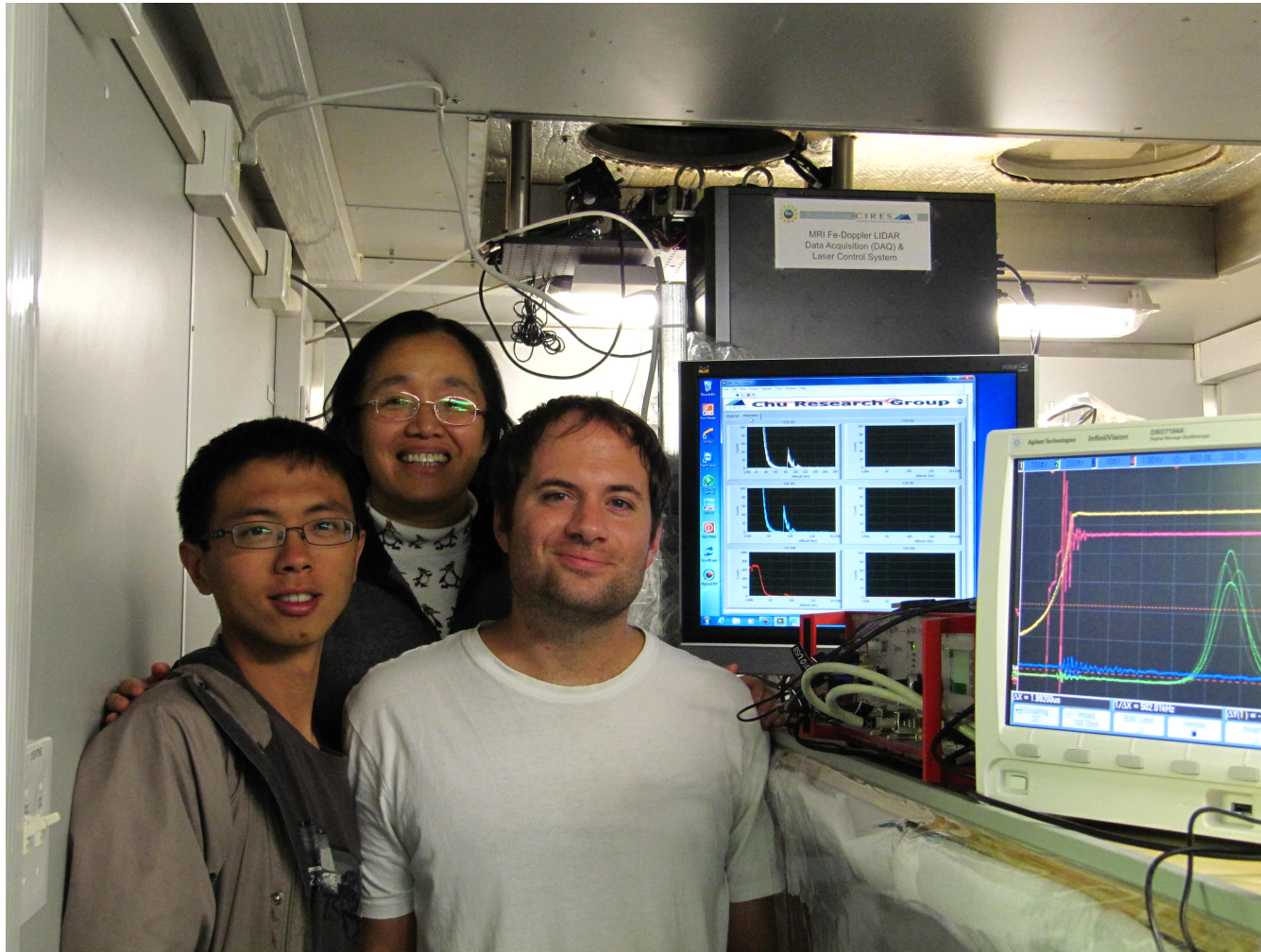

Containerized MRI lidar - hard to take photos
Come to Table Mountain to see it by your own eyes!



Lidar Calibration

- ❑ Lidar calibration is a difficult issue for cases when we try to push technology/measurement envelope, because existing instruments have not been able to achieve what you design to achieve. For these cases, you have to fully understand your own system and the entire lidar sensing procedure, including every possible interaction or process involved, and then do a thorough analysis on all possible measurement errors (accuracy, precision, resolution, and stability). **Primary vs. secondary atomic clocks**
- ❑ Understanding your own system and entire procedure is also the key for all cases of lidar calibration. A self-calibration must be made before cross-calibrations with others.
- ❑ Make sure your lidar system and data processing are **human-error-free!**
- ❑ In all cases, try to find any possible existing measurements (even not as accurate or resolution as yours) and theoretical/model predictions, and then compare your measurements with them to figure out the similarity and differences. Then analyze the reasons why so.
- ❑ Try to operate your lidars with an existing lidar or lidars or other instruments simultaneously and in common-volume, and then compare the measurement results. Be aware of the limitation of each instrument.



Lidar Calibration

- ❑ Design your measurements so that you can have some internal calibration or at least do some reality check. For example, temperature profile is usually stable but wind is highly variable. Simultaneous temperature and wind measurements can help determine whether the measurements make sense.
- ❑ Before the full system calibration, you may want to calibrate each individual pieces, e.g., PMT, filter, laser, etc. Is your PMT or APD saturated? How is your filter function like and is it stable? How is your laser lineshape like and is it stable? Is there any component in your lidar having day-to-day variability?
- ❑ For spaceborne or airborne lidars, it may be necessary to set up some ground-based calibration points. Flight over-passes some ground-based lidar stations for simultaneous and common-volume measurements or over-pass some known objects for altimeter calibration.
- ❑ If possible, compare with some in-situ measurements.



Summary

- ❑ Lidar architecture is the art of lidar instrumentation, concerning the lidar hardware and software, lidar configuration and arrangement, etc.
- ❑ Lidar architecture consists of lidar transmitter, receiver, and data acquisition and control system. Some have merged transceiver. Basic lidar configurations are bistatic and monostatic configurations. Basic lidar arrangements are biaxial and coaxial arrangements.
- ❑ Learning existing lidar systems is a good approach to understand the lidar architecture in depth, especially experiences and issues. It will help the design of a new lidar system.
- ❑ Lidar design is based on the understanding of physical interactions and processes involved, the lidar simulations, and the choices of lidar type, configuration, arrangement, hardware and software to design a lidar that meets the measurement goals (subject, accuracy, precision, resolution, reliability, coverage, etc).



Summary

- ❑ Besides basic architecture, configuration, and arrangement, more considerations should be given to the selection of **wavelengths** (specific request and solar spectrum intensity), **bandwidth** of transmitter and receiver (application needs - spectral resolved or not, nighttime-only or full diurnal cycle), laser power/energy, repetition rate, pulse duration time, receiver area, detector efficiency and capability, data acquisition software, and system timing and coordination control. Cost, volume, mass, reliability, etc will also be important when come to reality.
- ❑ Careful lidar simulations, laser design, optical design, frequency control, receiver design, DAQ design, etc. are the key to achieve the best performance of a lidar. ZEMAX optical modeling is shown to be a powerful tool to improve lidar optical efficiency.
- ❑ Lidar calibration is an important but challenging issue. Thorough understanding of your own lidar system and the entire lidar sensing procedure is the key step to calibrate your lidar. Then comparison with other lidars or other instruments is usually necessary for cross-calibration and at least reality check.