



# Lecture 03. Fundamentals of Lidar Remote Sensing (1)

- Introduction
- History from searchlight to modern lidar
- Various modern lidars
- Determination of Altitude and Range
- Summary and Questions



# Introduction: Lidar

- ❑ LIDAR is the acronym of Light Detection And Ranging -- laser radar in light frequency range or optical radar.
- ❑ Although lidar and radar share similar detection principles, large differences exist in the physical processes, the treatment approaches, and the system hardware, due to the huge difference in the radiation frequencies used.
- ❑ Lidar uses the concept of photons, while radar applies the concept of electromagnetic waves.
- ❑ Lidar started in the pre-laser times in 1930s with searchlight beams, and then quickly evolved to modern lidars using nano-second laser pulses.
- ❑ Lidar development has been and is strongly connected with progress in optical and electronic technology, especially laser technology. Lidar has always been both a source and beneficiary of technological innovations.



# LIDAR History: Searchlight → Modern Lidar

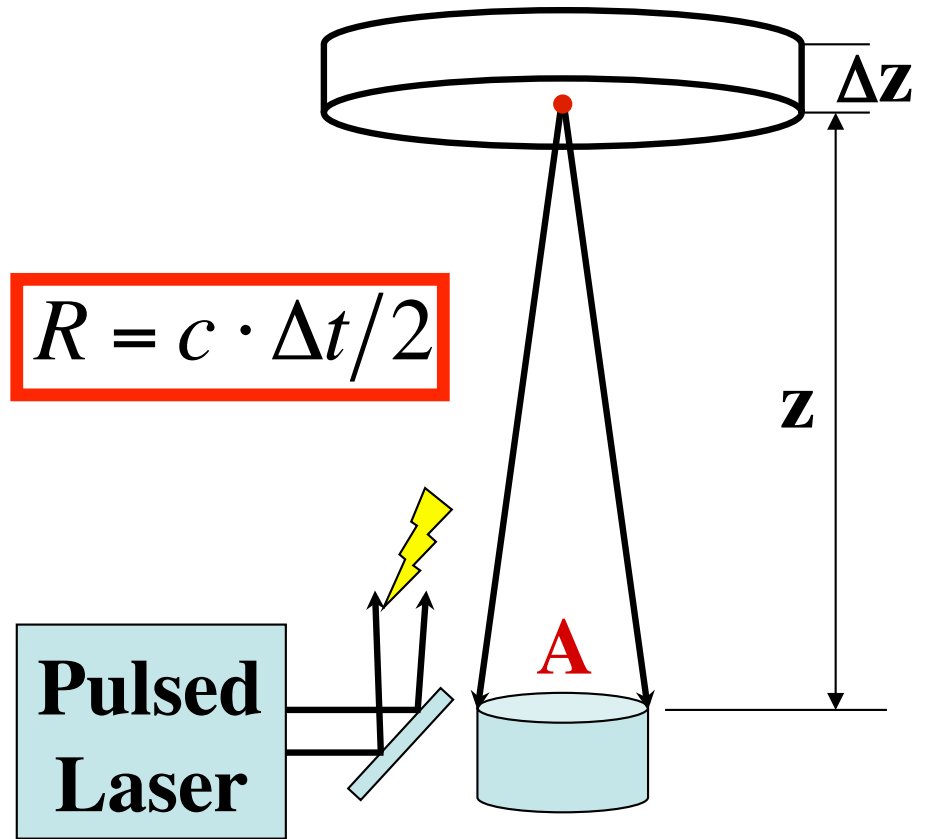
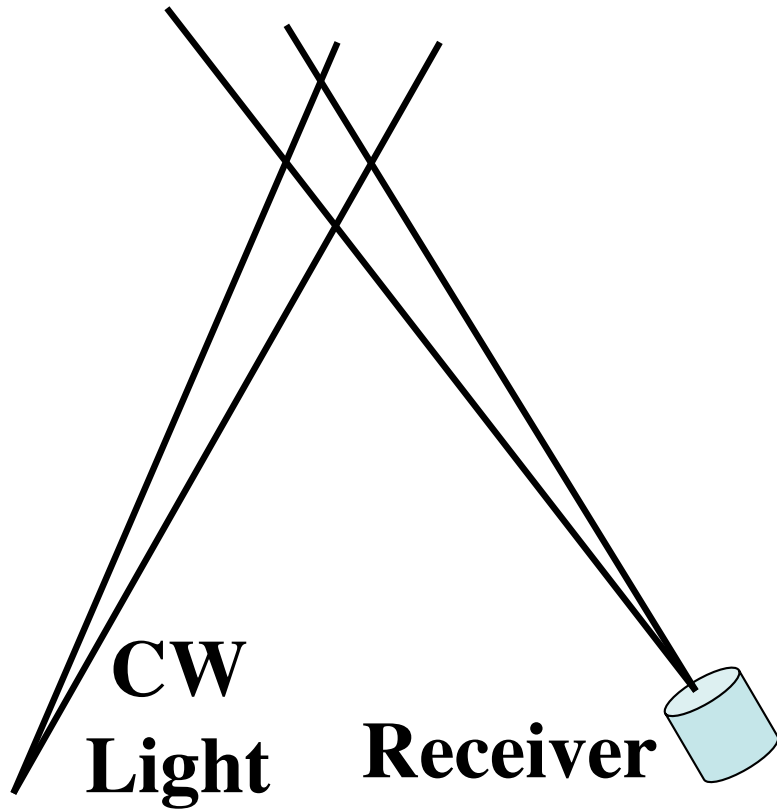

**Bistatic Configuration**

**Monostatic Configuration**

**CW searchlight → ns laser pulse**



# History: Searchlight Lidar

- ❑ Hulburt [1937] pioneered the aerosol measurements using the cw searchlight technique, who photographed the searchlight beam to 10 km.
- ❑ Johnson [1939] followed a proposal of Tuve et al. [1935] and modulated the searchlight beam with a mechanical shutter rotating at 10 cycles per second. Scattering to a height of 34 km was measured with good agreement between theory and experiment above 8 km.
- ❑ Elterman [1951, 1954, 1966] pushed the atmospheric study using searchlight to a high level and made practical devices.
- ❑ The idea of using cw light source for lidar has reoccurred in modern time when certain cw lasers become available with high power options.





# Lidar Started with Searchlight

□ Light Detection and Ranging (LIDAR) actually started with using the **CW searchlights** to measure stratospheric aerosols and molecular density in 1930s, well before the first (ruby) laser was invented in 1960.

Atmospheric aerosol and density measurements using searchlight tech.

Scattering light intensity is proportional to the atmosphere density in the aerosol free region

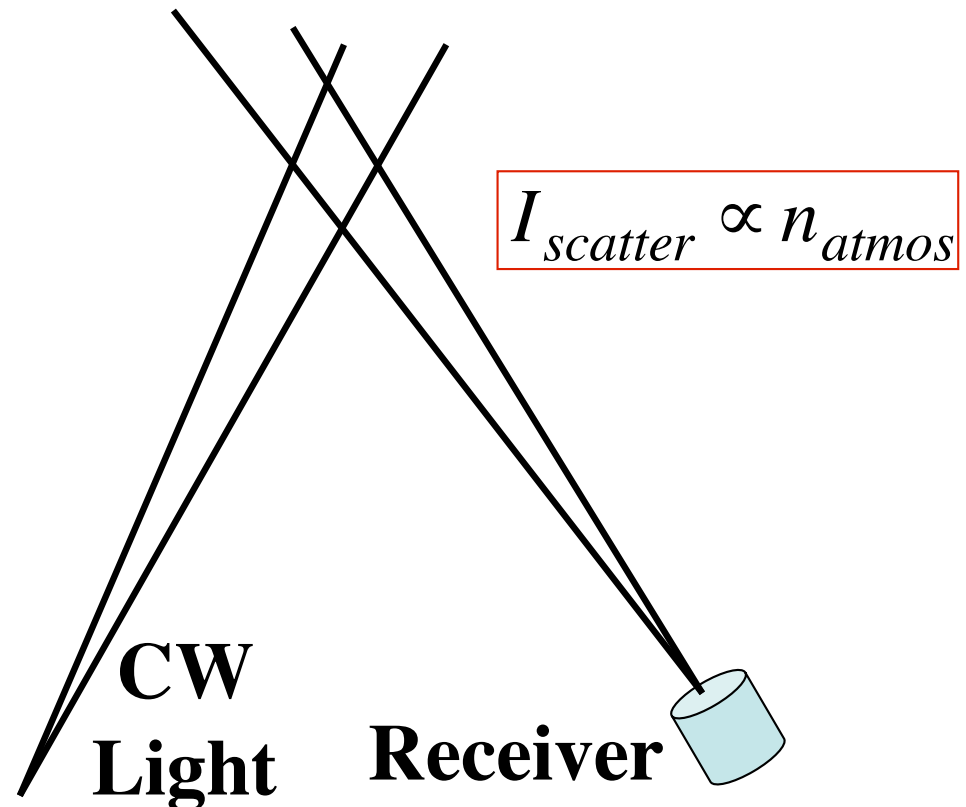



# Searchlight Lidar

$$\theta_T = 75^\circ$$

$$\theta_R = 0^\circ - 57^\circ$$

$$H_T = 1.39 \text{ km}$$

$$H_R = 2.76 \text{ km}$$

$$d = 30.2 \text{ km}$$

$$h = 2.76 \text{ km} - 35.3 \text{ km}$$

Transmitter  
(Projector)  
Angle fixed

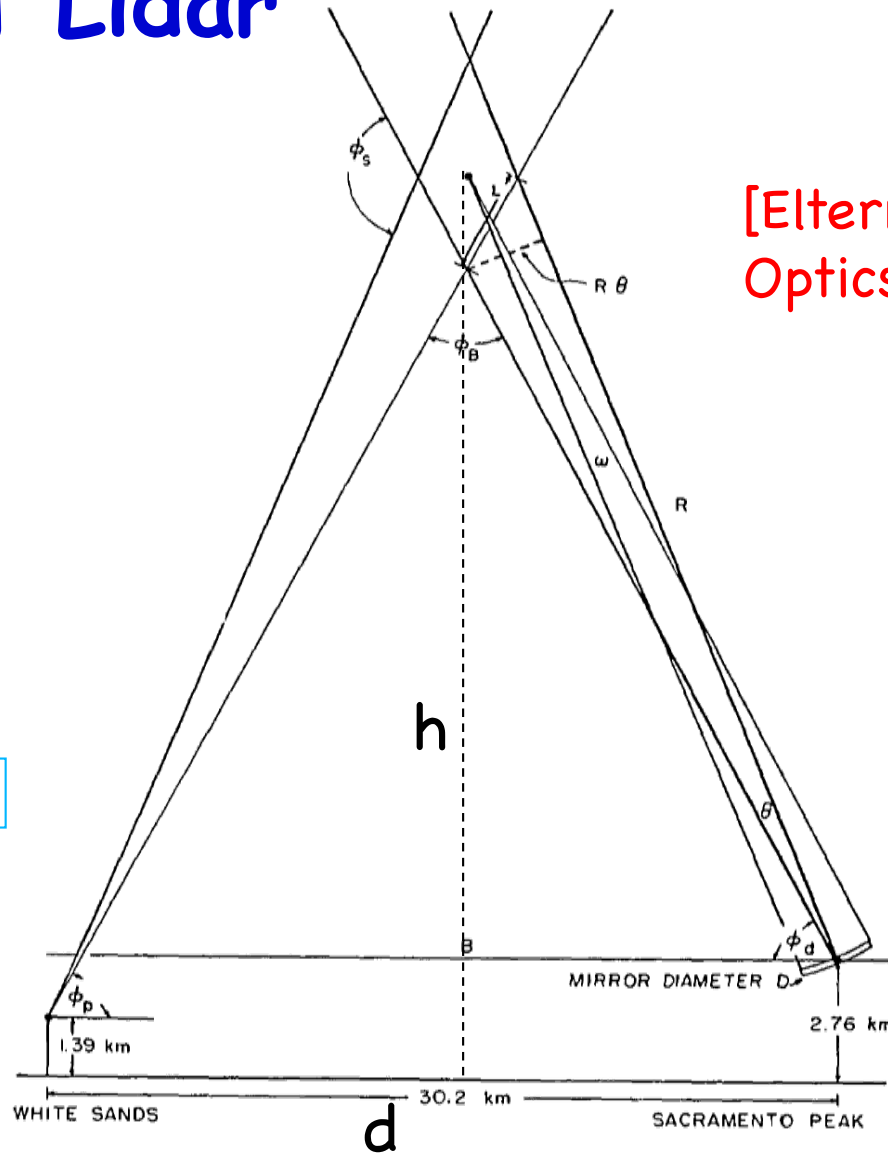

[Elterman, Applied Optics, 1966]

Receiver  
(Collector)  
Angle scanning

$$h = \frac{d \cdot \tan(\theta_T) \cdot \tan(\theta_R) + H_T \cdot \tan(\theta_R) + H_R \cdot \tan(\theta_T)}{\tan(\theta_T) + \tan(\theta_R)} \quad (3.1)$$



# Photographing vs. Modulation

## -- DC detection vs. AC detection

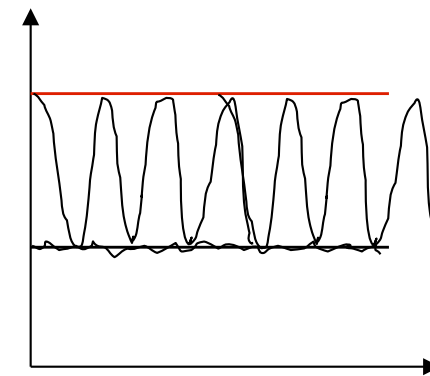
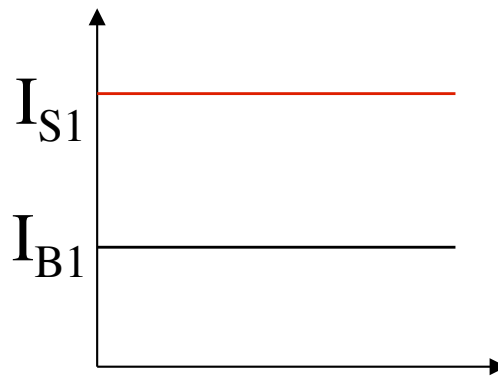
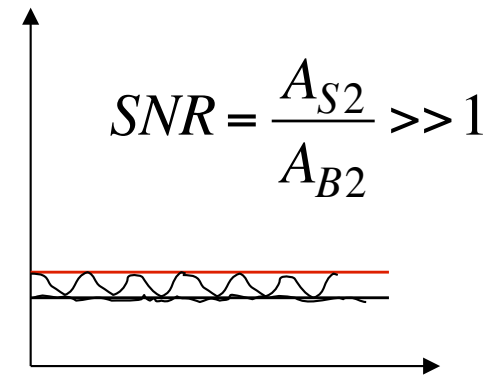
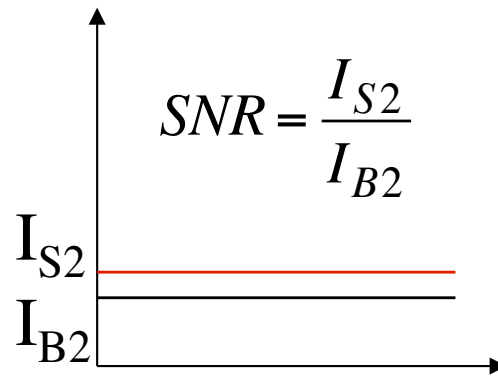
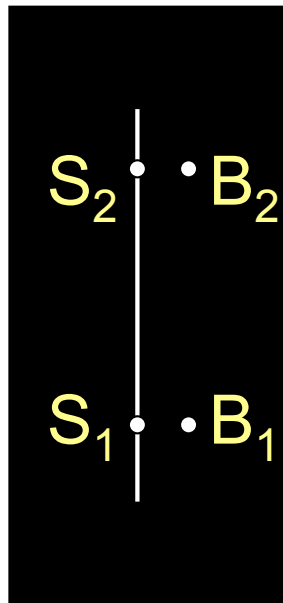

Although night-sky may still have quite strong background (DC), its AC component at the modulation frequency is very small, while the searchlight is much stronger at the modulation frequency. Therefore, the AC detection of modulated searchlight dramatically improves the SNR, resulting in higher detection range.



# Density measured by searchlight

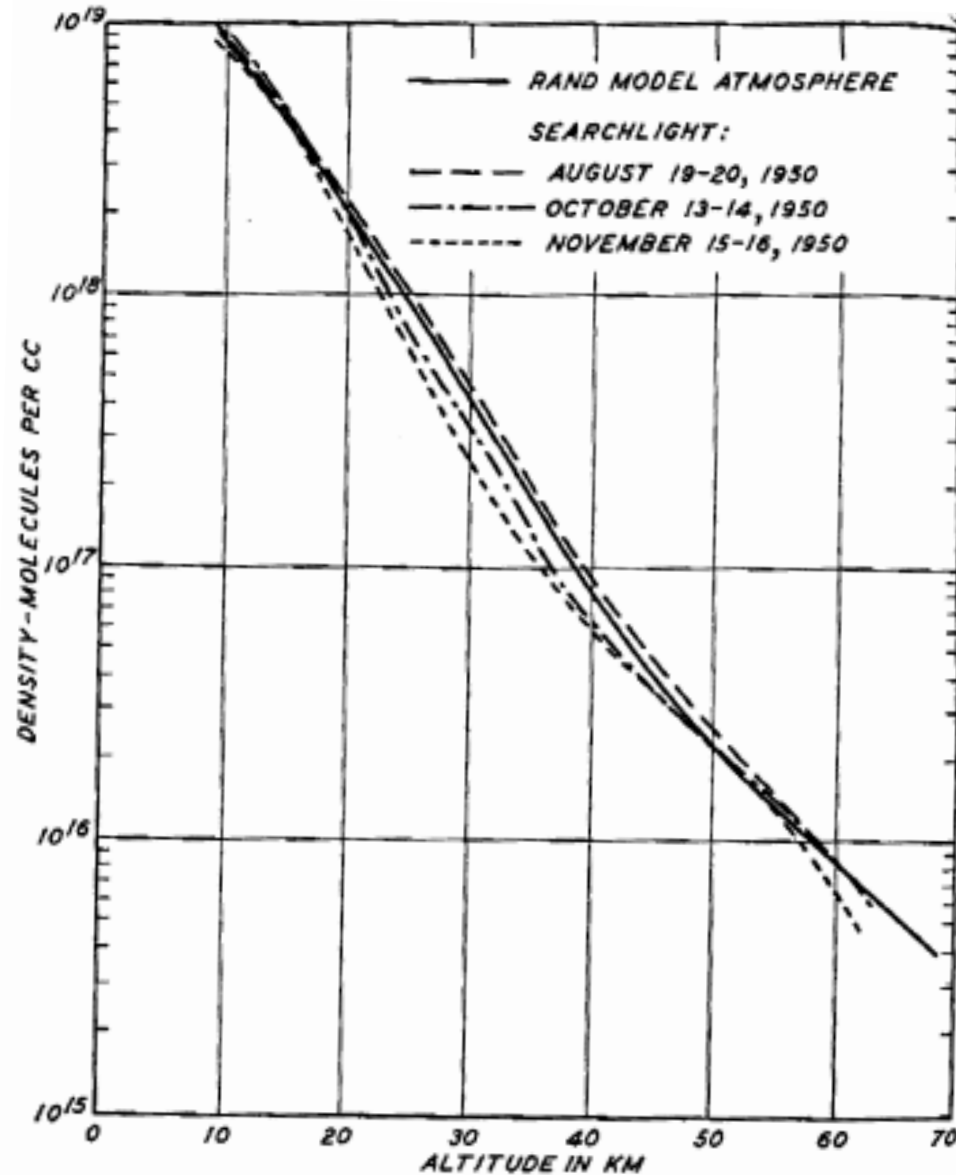

FIG. 4—DENSITY DISTRIBUTION FROM SEARCH-LIGHT DATA

Elterman [1951]



# CCD-Imaging Lidar with Similar Idea

- ❑ Modern CCD-imaging lidar utilizes an similar idea as the searchlight lidar.
- ❑ The bistatic lidar allows cw lasers to be used as the transmitter sources.

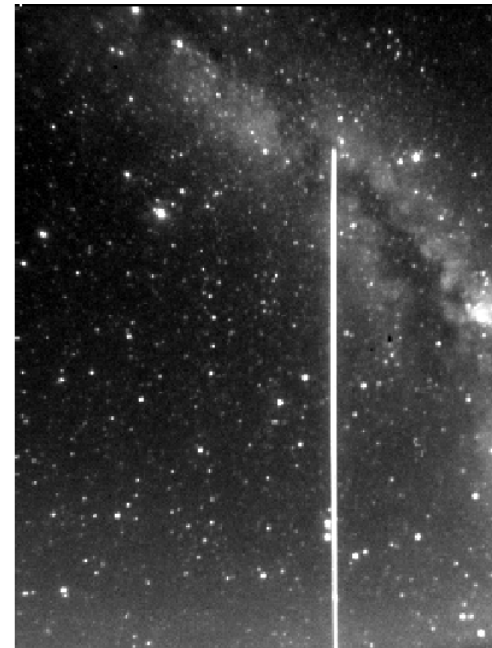
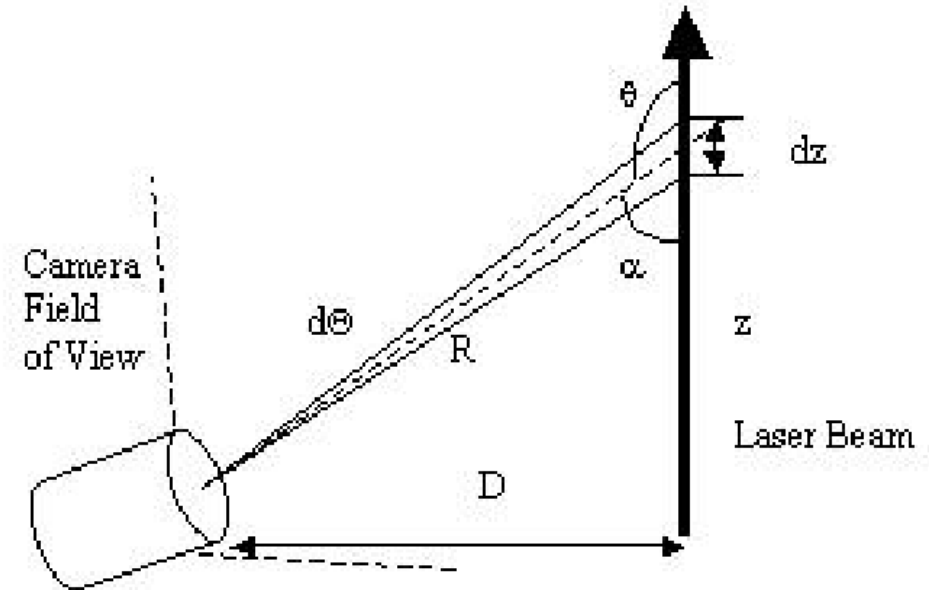

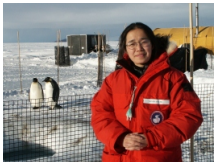

# History: Modern Lidar

- ❑ The first laser - a ruby laser was invented in 1960 by Schawlow and Townes [1958] (fundamental work) and Maiman [1960] (construction).
- ❑ The first giant-pulse technique (Q-Switch) was invented by McClung and Hellwarth [1962].
- ❑ The first laser studies of the atmosphere were undertaken by Fiocco and Smullin [1963] for upper region and by Ligda [1963] for troposphere.
- ❑ Following this, great strides were made both in the development of lidar technologies and instrumentation, and in the sophistication of their applications.
- ❑ There are two major categories of lidar: one is to detect atmospheric properties (atmospheric lidars) and another is to detect non-atmosphere objects - let's call them target lidars.



# Modern Lidar: Atmosphere Lidar

- ❑ The first application of lidar was the detection of atmospheric aerosols and density. Basically, it is to know whether there are aerosols/density in the regions and how much. However, the composition of atmosphere cannot be told, because only the scattering intensity was detected but nothing about the spectra.
- ❑ An important advance in lidar was the recognition that the spectra of the detected radiation contained highly specific information related to the species, which could be used to determine the composition of the object region.
- ❑ Furthermore, the utilization of Doppler effect and Boltzmann distribution lead to more sophisticated spectral analysis for wind and temperature measurements.





# Lidar Observations of Cosmic Dust

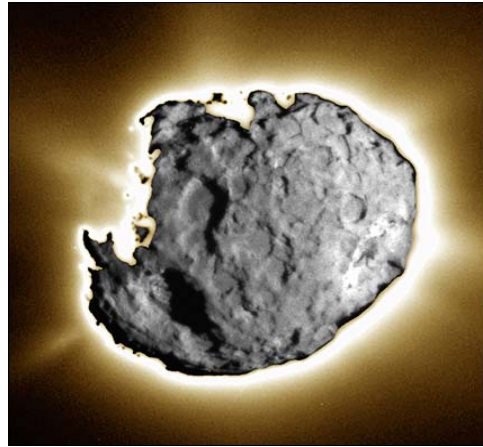

## Catching Meteors during Leonid 1998

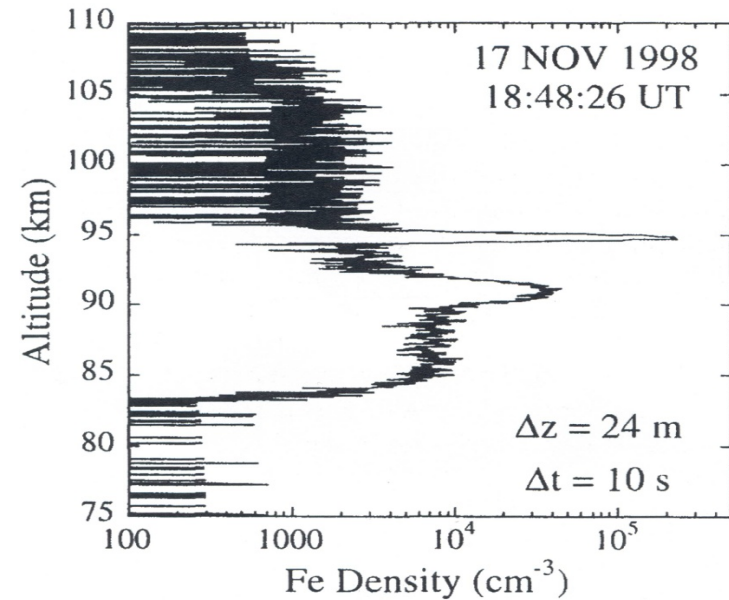
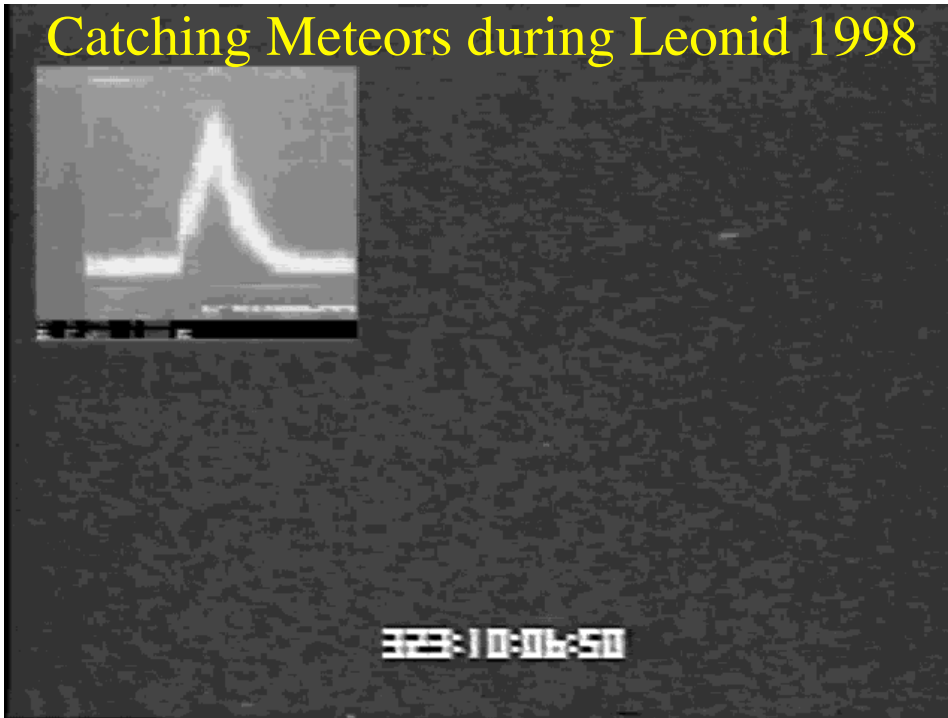

Profile on an Fe meteor trail measured by lidar [Chu *et al.*, GRL, 2000b]

Still a big debate on the daily mass input of meteor to the Earth : from 2 to 300 tonnes.



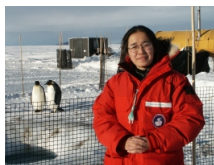

# Modern Lidar Advancement

- ❑ The broad selection of laser wavelengths became available and some lasers could be precisely tuned to specific frequencies. High-spectral-resolution filters became available along with modern data acquisition and processing technology. All these advancements enhanced the effective spectral analysis of the absorption features of objects and the returned radiation from objects.
- ❑ This ability added a new dimension to remote sensing and made possible an extraordinary variety of applications, ranging from probing of the trace-constituent distribution as well as temperature and wind in the upper atmosphere (**resonance fluorescence lidar**), to lower atmosphere constituents (**differential absorption lidar** and **Raman lidar**), boundary layers, wind and temperature (**coherent Doppler lidar** and **direction-detection lidar**), to airborne chlorophyll mapping of the oceans to establish rich fishing areas (**fluorescence lidar**).



# Atmosphere Lidar

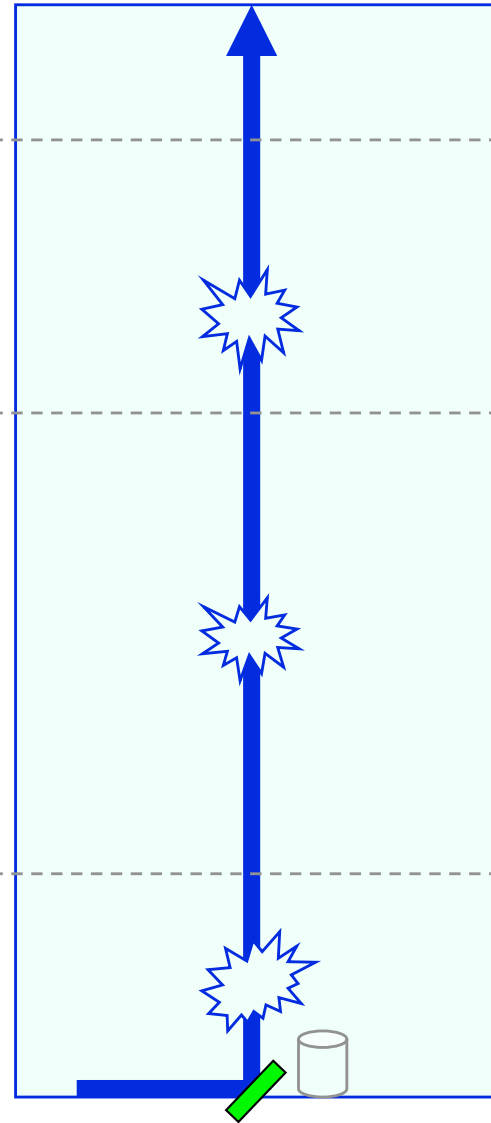
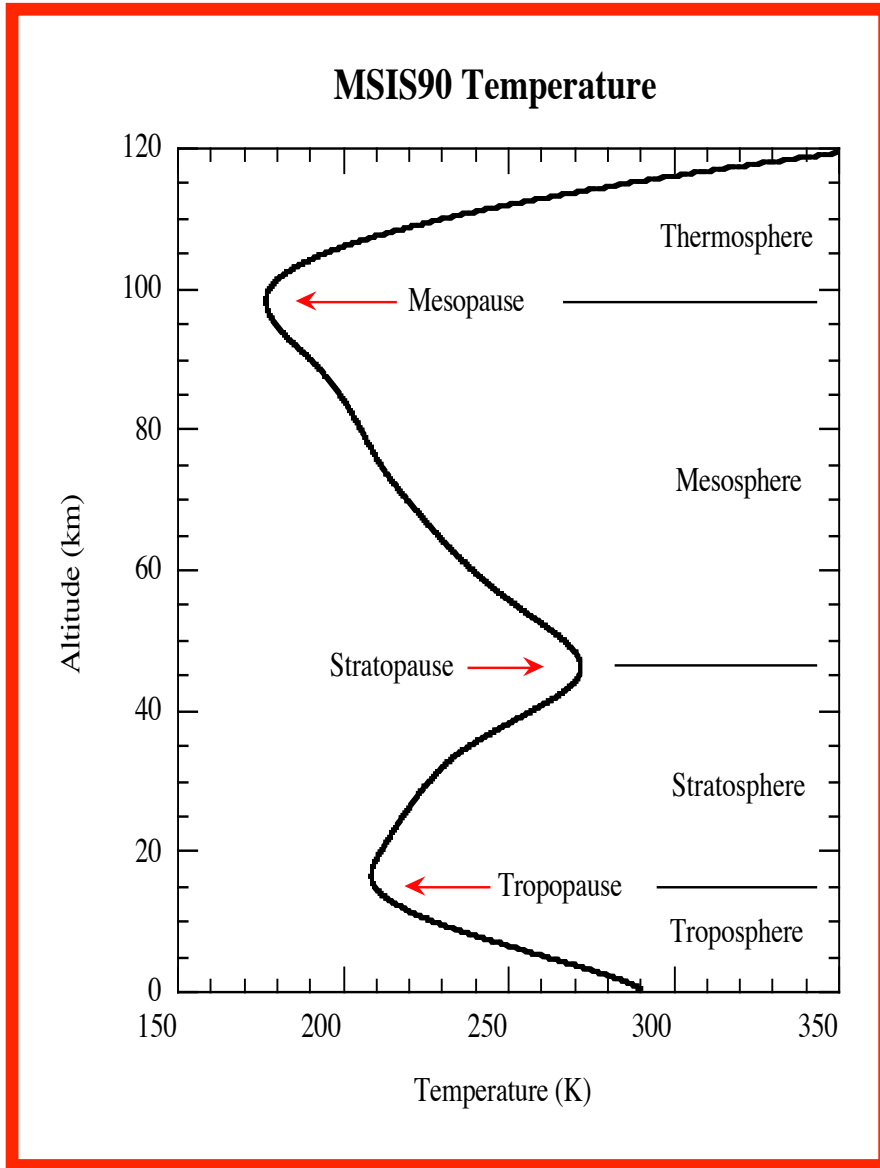

**Resonant  
Fluorescence  
From Metal Atoms**

**Rayleigh Scattering  
From Air Molecules**

**Mie Scattering  
From Aerosols**

**Range Determined From Time-of-Flight:  $R = c \cdot \Delta t / 2$**



# Typical Atmosphere Lidar Profile

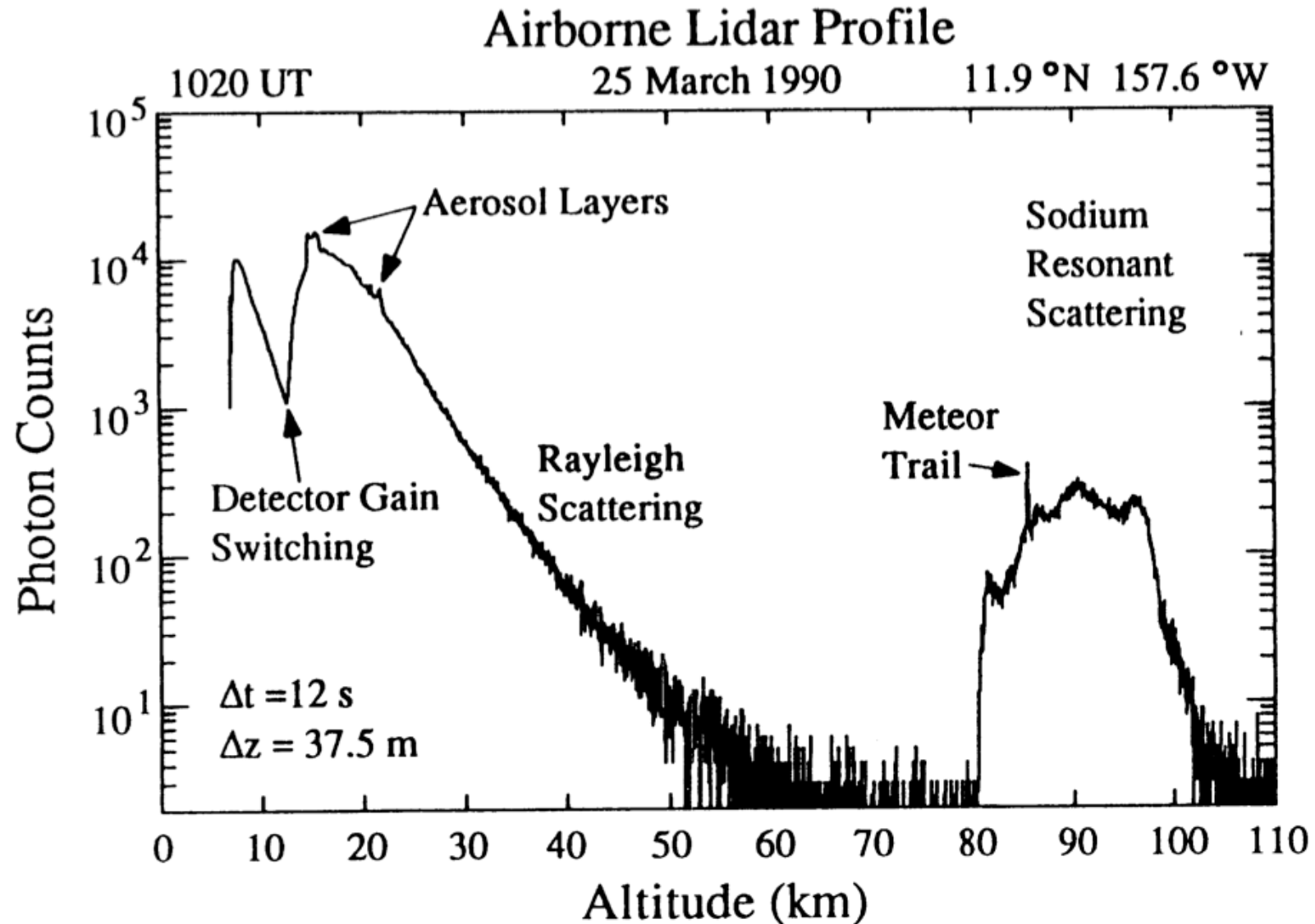



# Modern Lidar: Target Lidar

- ❑ Besides atmosphere, our environment includes many other things, like the solid earth, cryosphere, hydrosphere, and non-gas-phase objects on the earth, in the ocean, and in the air (e.g., plants, oil, buildings) etc. Study of our environment demands good measurement technologies and approaches for measurements in all sorts of occasions. Therefore, lidar technology for target (anything other than gas phase objects) detection is important and highly demanded.
- ❑ Two main categories for target lidars: (1) lidars for ranging (laser range finder, laser altimeter) and (2) lidars for species identification (laser-induced-fluorescence lidar).
- ❑ Lidar has two major functions: one is to identify species and measure their properties like density along with environmental conditions like temperature and wind, etc. along with their range distributions, and another is to determine the range/altitude very precisely.



# Laser Range Finder

- ❑ Laser range finder belongs to the second type, mainly concerning about the range information.
- ❑ The time-of-flight information from a lidar system can be used for laser rangefinding / laser altimetry from airborne or spaceborne platforms to measure the heights of surfaces with high resolution and accuracy.
- ❑ Downward-pointing laser systems were operated in a mode where surface scattering and reflection represented the dominant form of interaction.
- ❑ The reflected pulses from the solid surface (earth ground, ice sheet, vegetations, etc) dominant the return signals, which allow a determination of the time-of-flight with much higher resolution than the pulse duration time.



# Laser Altimeter

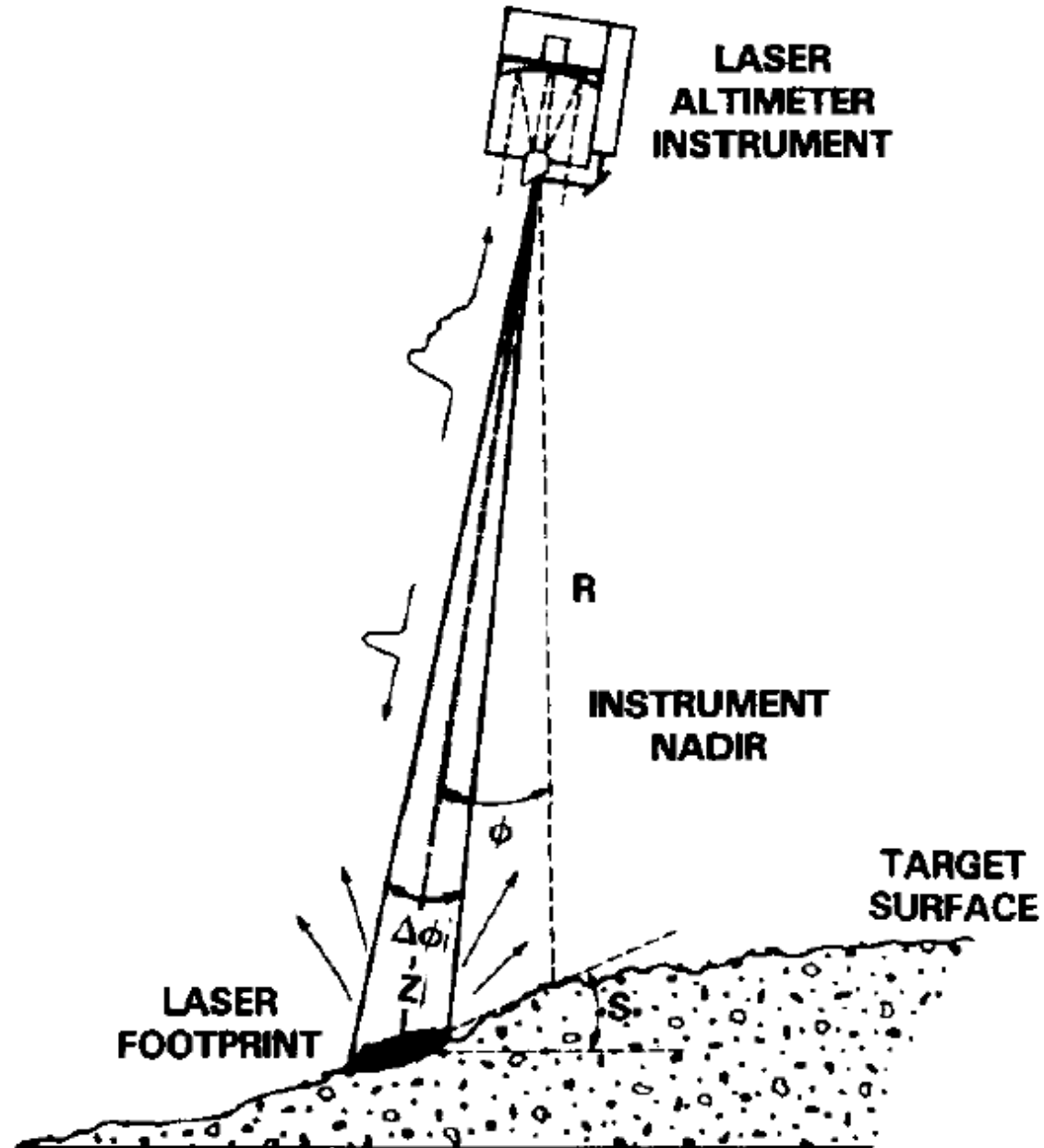



# Lidar for Hydrosphere

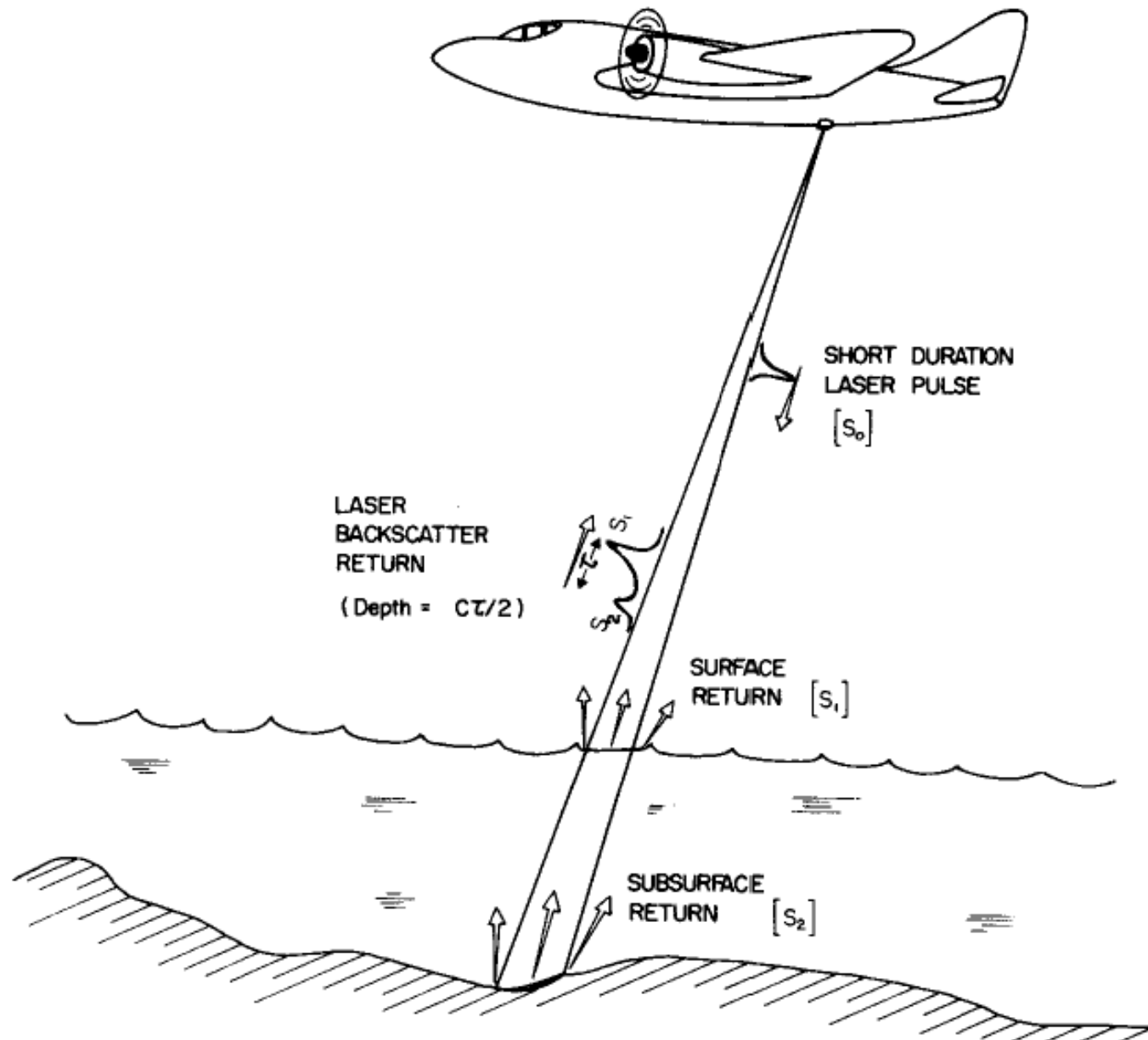



# Laser Altimeter vs Radar Altimeter

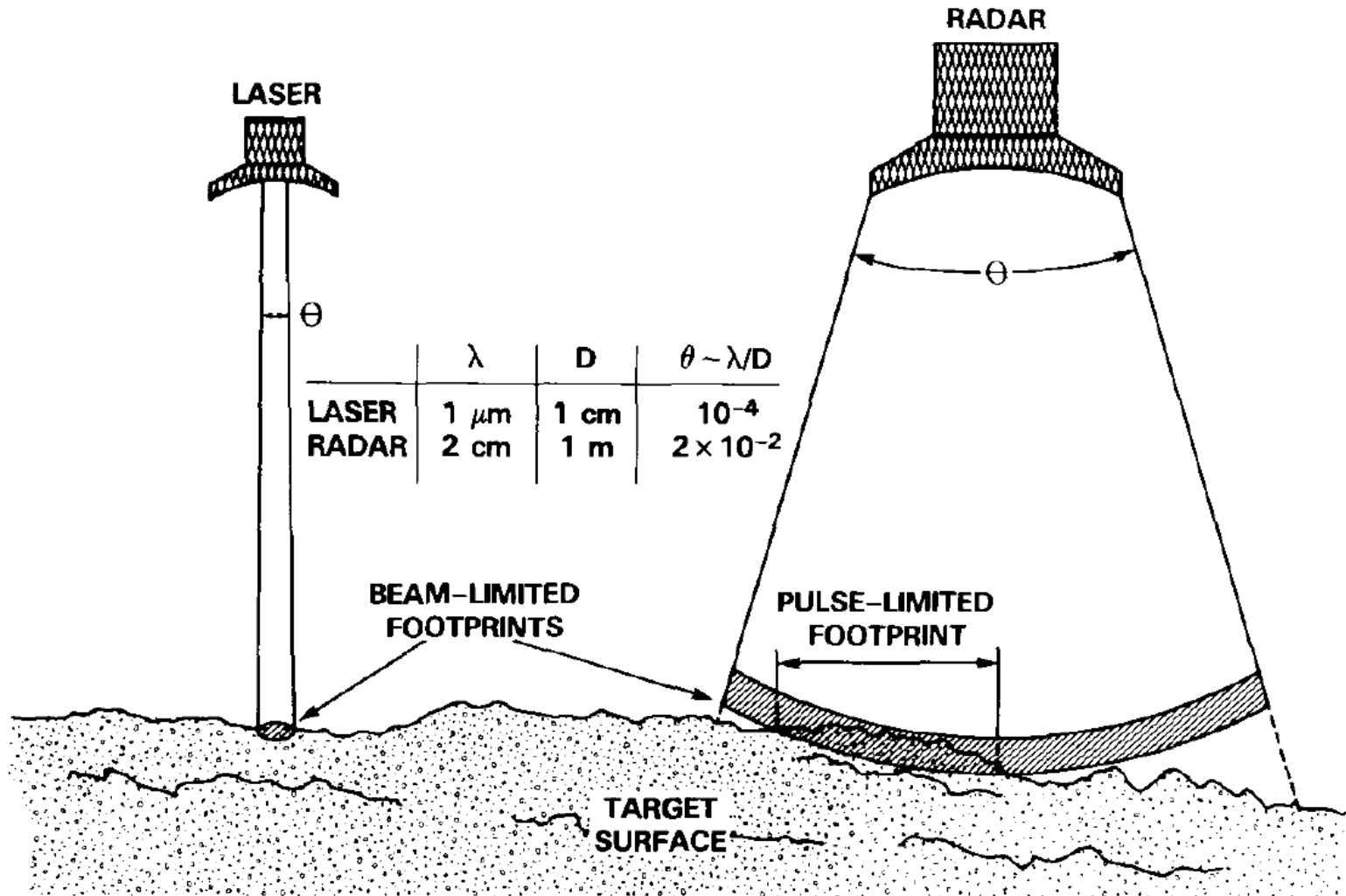

Lidar has much better resolution and precision.





# Fluorescence Lidar

- ❑ A notable advance was made with the realization that use of a short-wavelength laser could broaden the spectrum of applications, as a result of laser-induced fluorescence, and led to the development of a new form of remote sensor “laser fluorosensor” or “fluorescence lidar”.
- ❑ The fluorescence signal could indicate the presence of high organic contamination and enable the dispersion of various kinds of effluent plumes to be remotely mapped.
- ❑ Fluorescence lidar has also been used to detect insects and birds, as reported at the 25<sup>th</sup> International Laser Radar Conference (ILRC) in St. Petersburg, Russia and at the 26<sup>th</sup> ILRC in Porto Heli, Greece.



# Scenarios for Fluorescence Lidar

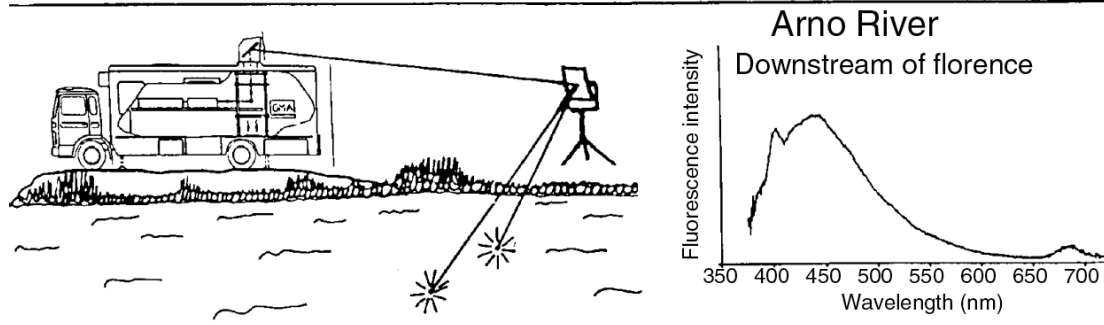

Aquatic monitoring  
Via folding mirror

A

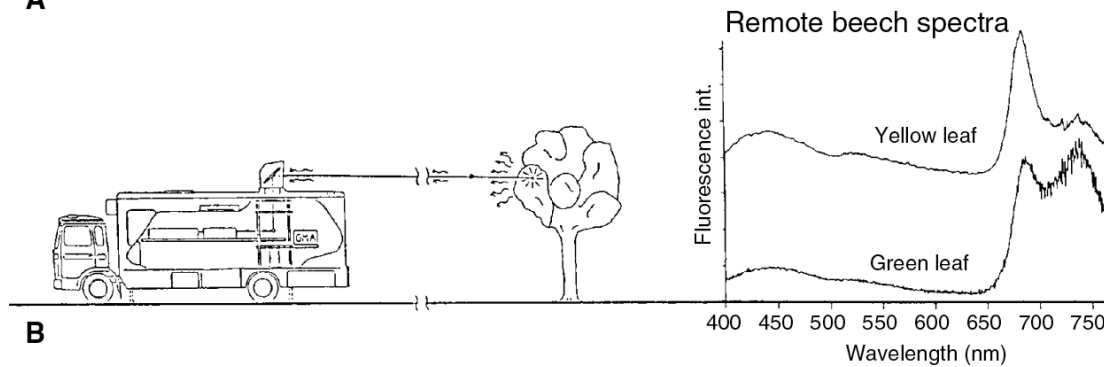

Vegetation  
Monitoring

B

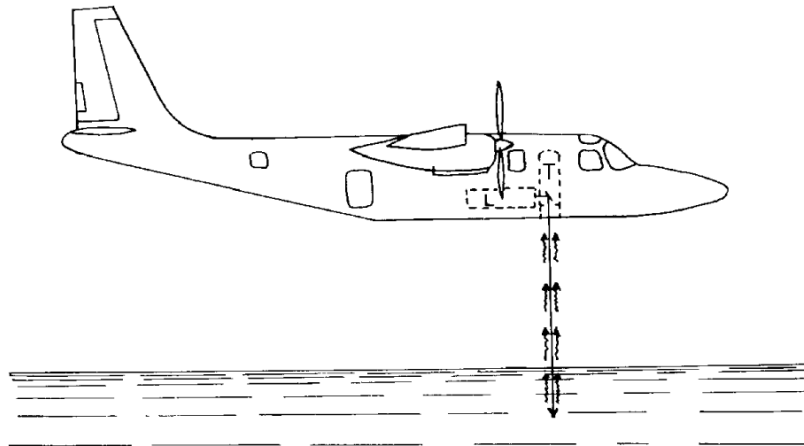

Airborne  
Fluorescence

C



# Detection of Historic Monument

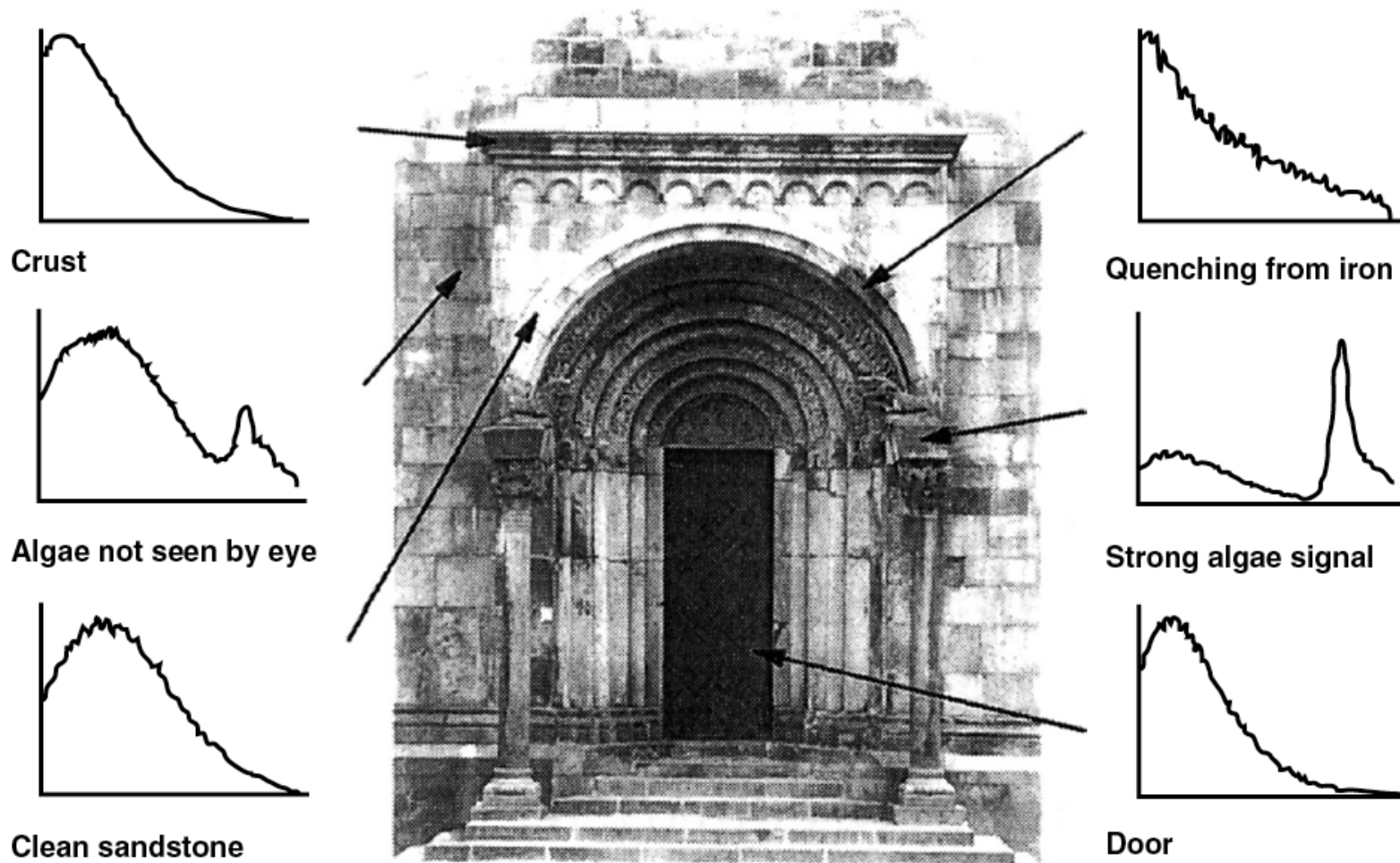

**Figure 6.13** Photograph of the northern gate of the Lund Cathedral and six remotely recorded fluorescence spectra. (From Weibring, P. et al., *Appl. Opt.*, 40, 6111, 2001. With permission.)



# Determination of Altitude and Range

□ Searchlight lidar, cw laser lidar, and CCD-imaging lidar: determine altitude through the geometry calculation.

$$h = \frac{d \cdot \tan(\theta_T) \cdot \tan(\theta_R) + H_T \cdot \tan(\theta_R) + H_R \cdot \tan(\theta_T)}{\tan(\theta_T) + \tan(\theta_R)}$$

(3.1)

Pseudo-random coding has been proposed for lidar employing cw laser, in analogy with radar technique, along with various ways of simulating pulses ...

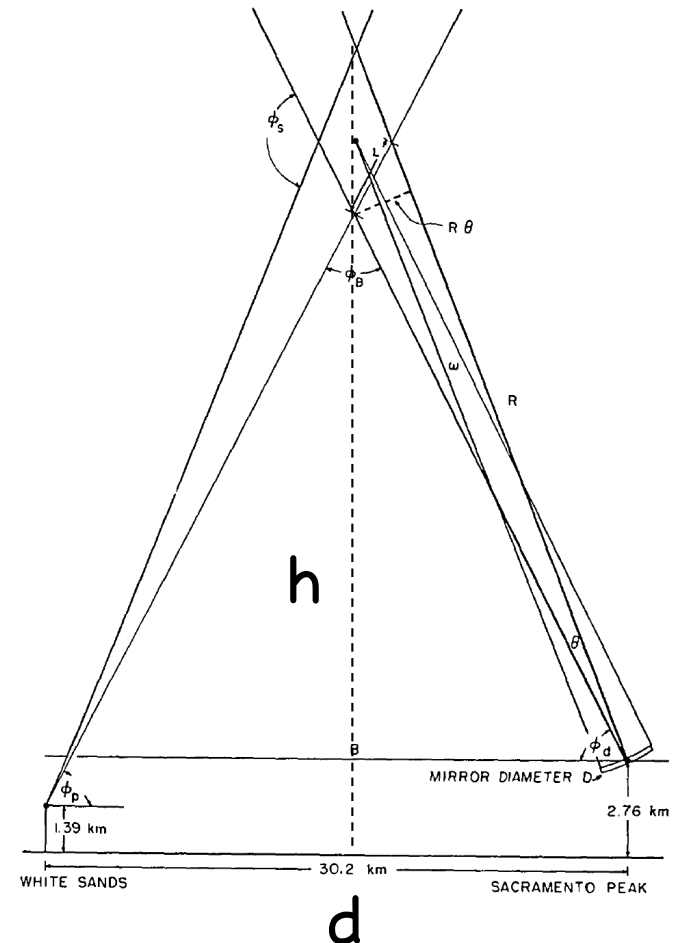

# Range Determination from TOF (Distributed Scatters)

- ❑ **Modern atmosphere lidars:** Due to the use of nanosecond pulse lasers, the range can be determined by the time-of-flight through equation  $R = c \cdot \Delta t / 2$ , where  $c$  is the light speed in the medium,  $\Delta t$  is the time-of-flight, and 2 for the round-trip of the photons traveled.
- ❑ Because atmospheric scatters are distributed sources, i.e., scattered signals are continuous, the ultimate resolution of range determination is limited by the pulse duration time  $\tau$ .
- ❑ Ultimate resolution:  $\Delta R = c \cdot \tau / 2$
- ❑ For example, a 5-ns pulse gives 75 cm as the highest resolution for an atmospheric lidar.



# More on TOF Range Determination

- When scatters are continuously distributed, the ultimate resolution of range determination is limited by the pulse duration time  $\tau$ :  $\Delta R = c \cdot \tau / 2$ .
- The distinct peak due to the strong reflection of light from surface or target, the range resolution can be significantly improved by digitizing the return pulse and compare shape.

How to understand these statements?

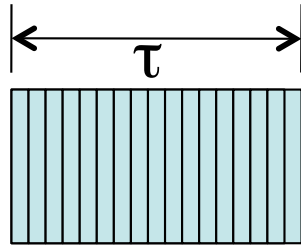

A pulse with long duration can be divided into many narrow pulses with sequentially delayed start times.

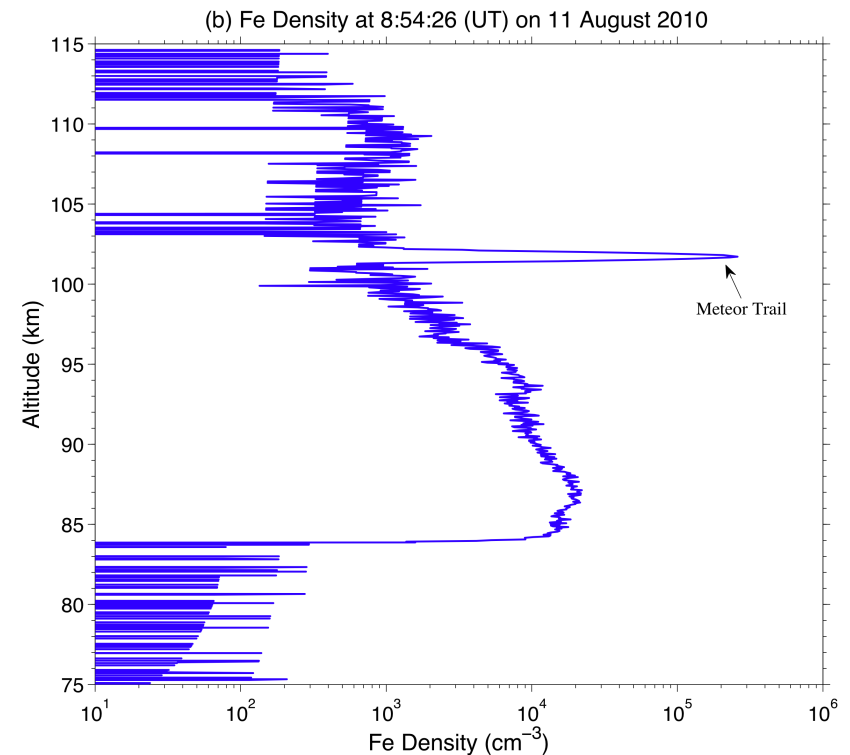





# More on TOF Range Determination

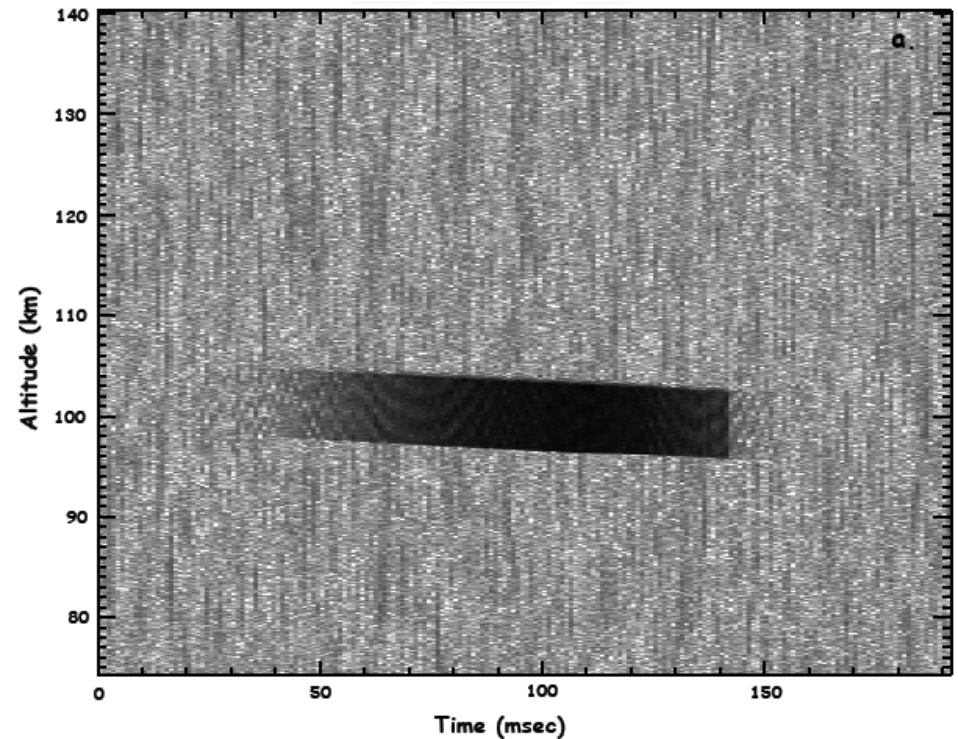
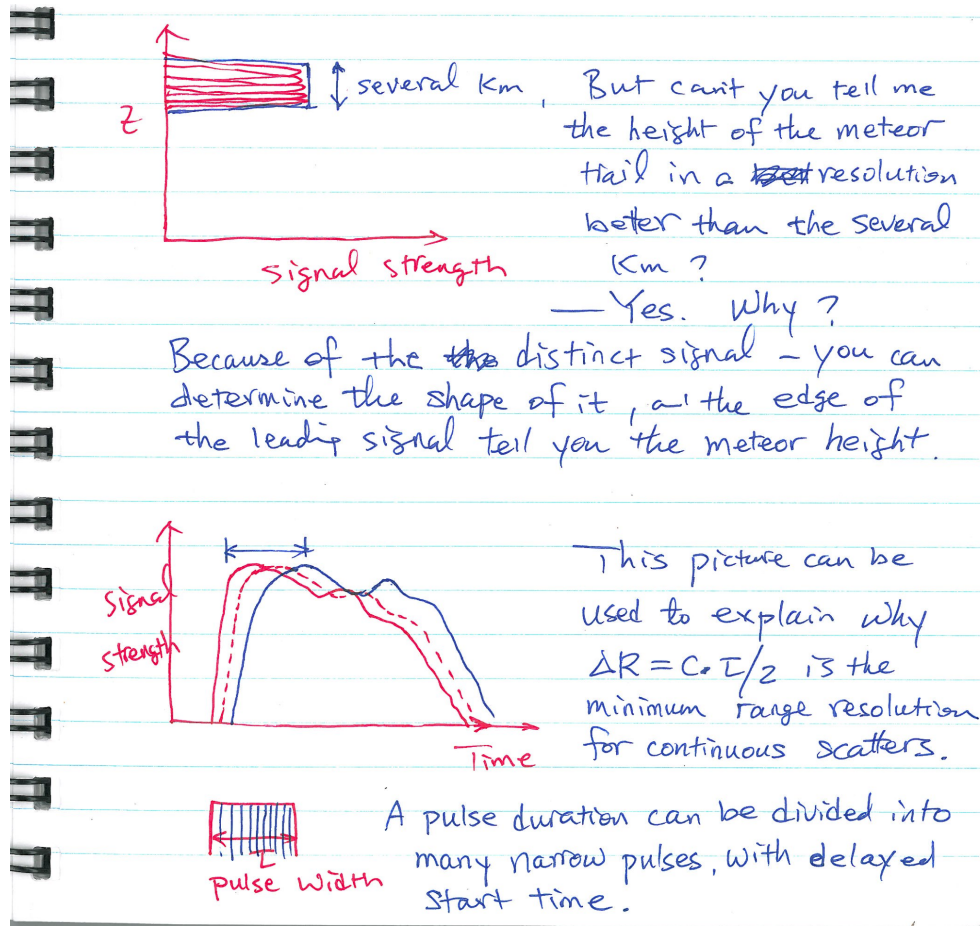

A meteor head echo recorded by Arecibo 430-MHz radar with a 45  $\mu$ s pulse (min  $\Delta R = 6.75$  km)

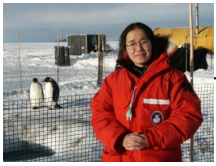

# Range Determination from TOF (Hard Target or Distinct Peak)

- ❑ **Target lidar - laser altimeter:** Distinct peak coming from the reflection of surfaces allows a more precise measurement of the time-of-flight through rising edge or peak comparison, thus enabling higher resolution than the pulse duration limitation.
- ❑ For example, a laser altimeter using 5-ns pulse duration can have better than 5 cm resolution and accuracy.
- ❑ Polarization lidar technique may help to further improve the time/range resolution under certain conditions. For example, in detection of a water body depth, if the water surface and bottom have different reflection properties, e.g., in terms of polarization, the detection of returned photons' different properties (e.g., polarization) in two channels can help resolve the depth in a much finer scale.





# Laser Altimeter and Ranging

□ For target lidar (e.g., laser altimeter), the distinct peak due to the strong reflection of light from surface or target, the range resolution can be significantly improved by digitizing the return pulse and compare shape.

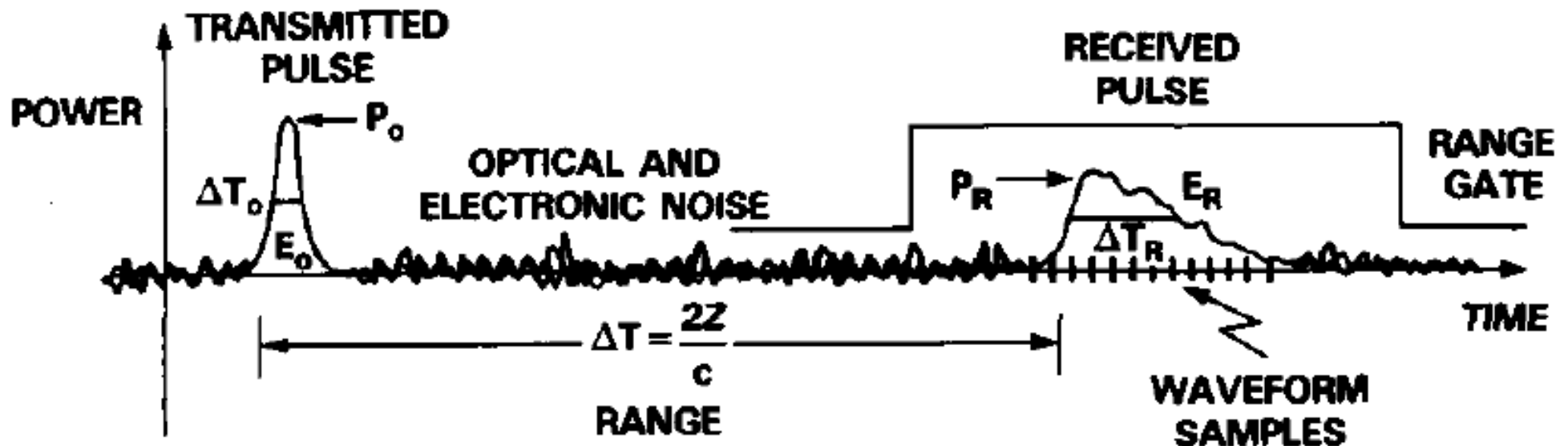

□ The resolution is now determined by the resolution of the timer for recording pulses, instead of the pulse duration width. By computing the centroid, the resolution can be further improved.



# Summary (1)

- ❑ LIDAR actually started with CW searchlight using geometry to determine altitude. The invention of lasers pushed lidar to a whole new level -- modern laser remote sensing. The time-of-flight of a short pulse is used to precisely determine range and altitude.
- ❑ Modern lidars have various formats from numerous atmosphere lidars to target lidars. Here target lidars refer to lidars that detect non-atmosphere objects, including hydrospheric lidar, fluorescence lidar and laser rangefinder like laser altimeter.
- ❑ Modern lidars utilize different approaches to determine altitude and range precisely:
  - (1) Geometry for searchlight or most cw lidars;
  - (2) Time of flight for ns pulse atmosphere lidar;
  - (3) Time of flight and digitized pulse shape comparison for laser range finder and laser altimeter.
  - (4) Multiple channels of time of flight to determine the difference in time of flight, e.g., for shallow-water hydrology lidar to determine depth.
  - (5) Focusing and scanning laser beam longitudinally to determine the range for CW coherent Doppler lidar.

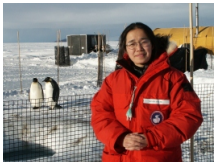

## Summary (2)

- ❑ Applications of spectroscopy knowledge and laser technology to lidar are the two main drivers that have significantly advanced the lidar field and are still driving the lidar innovation. You are encouraged to study fundamentals of spectroscopy.
- ❑ This class will provide qualitative overview of all types of lidars, and in the same time focus on quantitative analysis of several key lidars, like resonance fluorescence lidar, wind lidar, laser altimeter, polarization lidar for aerosol/cloud detection, etc.

How to understand these statements? How to derive the altitude from geometry?

- ❑ When scatters are continuously distributed, the ultimate resolution of range determination is limited by the pulse duration time  $\tau$ :  $\Delta R = c \cdot \tau / 2$ .

### Related Reading Materials

Chapter 1 of "Laser Remote Sensing" textbook

Chapter 5. Sections 5.1 and 5.2.1

Chapter 8. Sections 8.8 and 8.9

Chapter 9. Section 9.4