

Lecture 21. Wind Lidar (3)

Direct Detection Doppler Lidar

- ❑ Overview of Direct Detection Doppler Lidar (DDL)
- ❑ Resonance fluorescence DDL
- ❑ Fringe imaging DDL
- ❑ Scanning FPI DDL & FPI edge-filter DDL
- ❑ Iodine absorption-line edge-filter DDL
- ❑ Na or K DEMOF DDL
- ❑ New development of DDL at the 24th ILRC
- ❑ Comparison of Wind Techniques
- ❑ Summary

Direct Detection Doppler Wind

- ❑ Direct detection Doppler lidars (DDL) convert the Doppler frequency shift to the change of intensity, or intensity ratio, or intensity spatial distribution for wind measurements.
- ❑ One of the key components for non-resonance DDL is the optical frequency discriminator or frequency analyzer, usually implemented in the lidar receiver if it is not available in the atmosphere.
- ❑ Current available **optical frequency discriminators** include
 - (1) Fringe imaging with optical interferometers (Fabry-Perot or Fizeau)
 - (2) Scanning FPI: tune the FPI peak transmission frequency
 - (3) Interferometer edge-filter: the edge of a transmission fringe of an optical interferometer (e.g., Fabry-Perot etalon)
 - (4) Molecular absorption-line edge-filter (e.g., iodine I₂ absorption lines)
 - (5) Atomic absorption-line edge-filter (e.g., Na or K magneto-optic filter)
 - (6) Michelson or Mach-Zehnder interferometer with optical autocovariance
- ❑ A major difference between resonance DDL and non-resonance DDL lies in where the frequency discriminator is - in the atmosphere or in the receiver chain! Because the Na, K, or Fe absorption lines are in the atmosphere, the lidar receiver is allowed to be broadband, rather than the narrowband employed in the non-resonance DDL.

Consideration for DDL

- ❑ Precision requirement: for $\delta V = 1$ m/s velocity precision, the freq measurement precision required for the optical freq analyzer in a DDL is $\delta \nu = 2(\delta V)/\lambda = 5.6$ MHz for 355 nm.
- ❑ Accuracy requirement: accuracy should surpass the precision level. This is usually achieved by monitoring the transmitted laser pulse signal or alternatively measuring the backscatter signal from a stationary or very low velocity target or lock the laser and the filter transmission to each other.
- ❑ Calibration or accuracy is a main problem for non-resonance DDL, because the burden is on the receiver chain which is variable through time or surrounding conditions, especially in FPI case.
- ❑ On the other hand, resonance fluorescence Doppler lidars put the discriminator to the atomic absorption lines, which do not change with time. Their receivers can be much simpler.

Resonance Fluorescence DDL

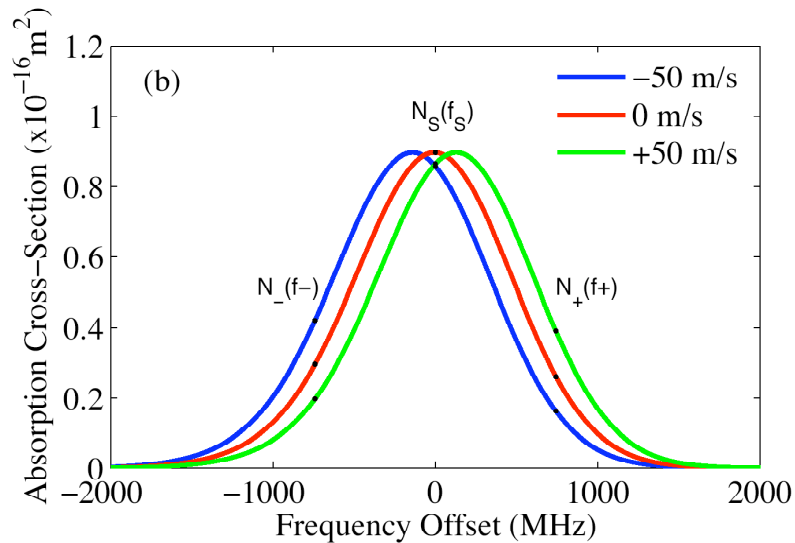
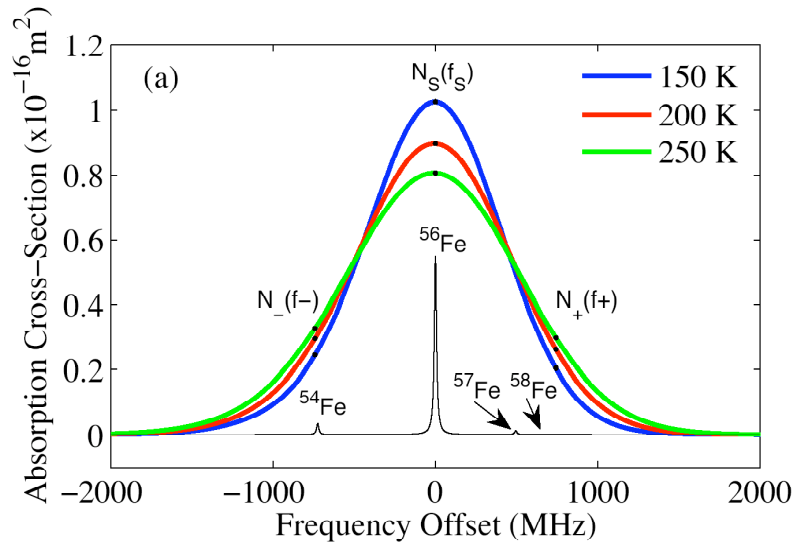

Fe Doppler Lidar

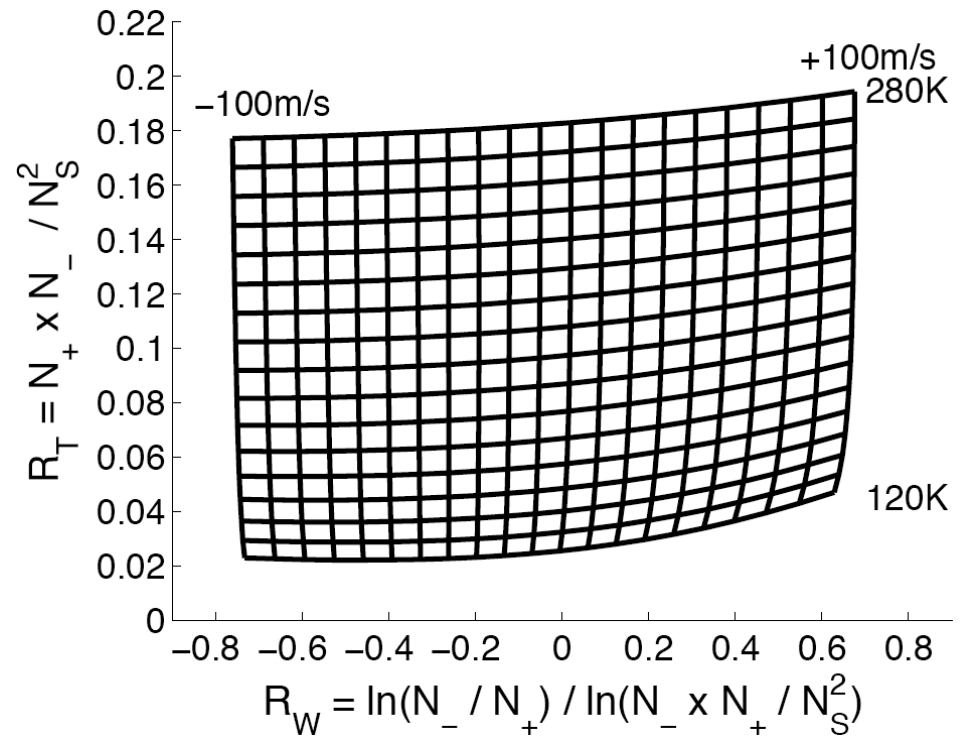

Atomic Fe absorption lines undergo Doppler frequency shift & broadening, so acting as an frequency analyzer/discriminator

Fringe-Imaging DDL

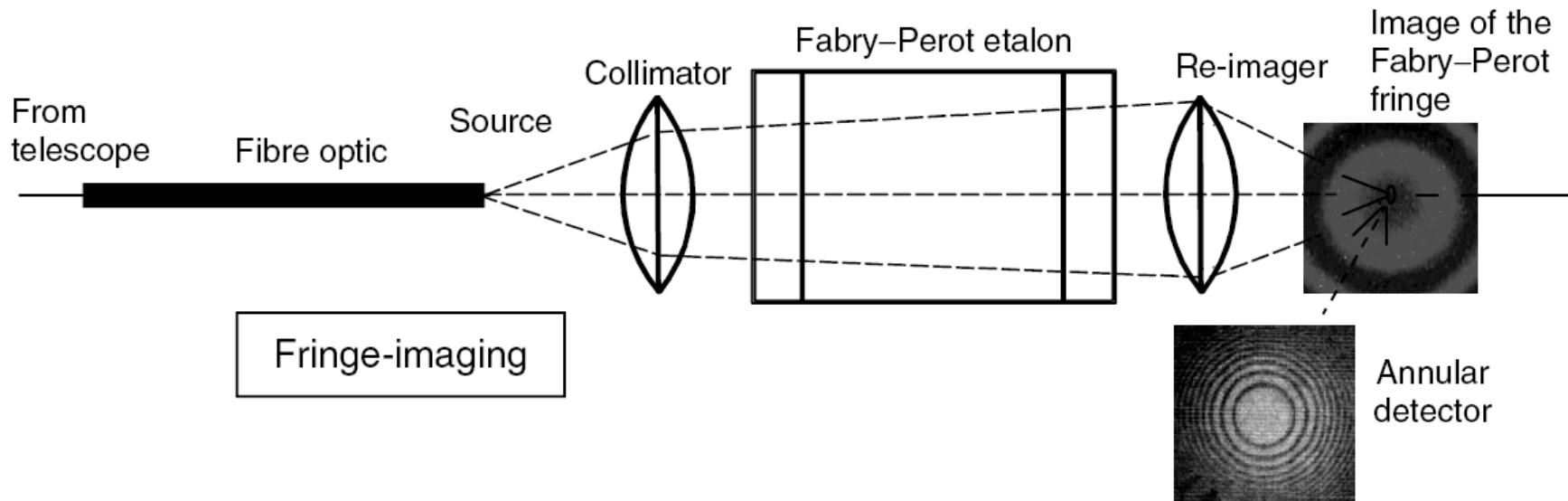

- ❑ The basic concept of fringe-imaging discriminator is to utilize a high-resolution interferometer to produce a spatial irradiance distribution, which is representative of the receiver-plane signal spectrum.
- ❑ In principle, fringe imaging can measure both wind (from frequency shift) and temperature (from fringe width).
- ❑ Similar to passive F-P Interferometer, the diameter of the concentric rings can be used to determine the frequency shift.

Detectors for Fringe Imaging DDL

- ❑ For the fringe-imaging technique, by its nature, a multi-element imaging detector is required. Furthermore, the detector has to be capable of being used in a **time-gated mode**, in order to provide the essential range-resolved sampling of the backscattered signal. There is a further subtle difficulty that the Fabry-Perot etalon presents its spectral information as concentric circular fringes.
- ❑ **3-D detection: spatial distribution, altitude range, and time**
- ❑ Multi-channel detectors like an imaging photomultiplier tube (IPD), incorporating a 24-channel concentric-ring anode read-out designed to match the fringe pattern presented by the F-P etalon. It uses a stack of microchannel plates to achieve high electronic gain. Each of 24-channel is time-gated to achieve range-resolved data.
- ❑ Circle-to-Line Imaging Optics (CLIO) can be used to convert the circular fringes formed by a F-P etalon into a linear pattern of spots. Then a conventional linear array detector, such as a CCD, can be used to read the linear fringe pattern.
- ❑ CCD response is slower than PMT and PD - problem in range resolution.

Circle-to-Line Imaging Optics (CLIO)

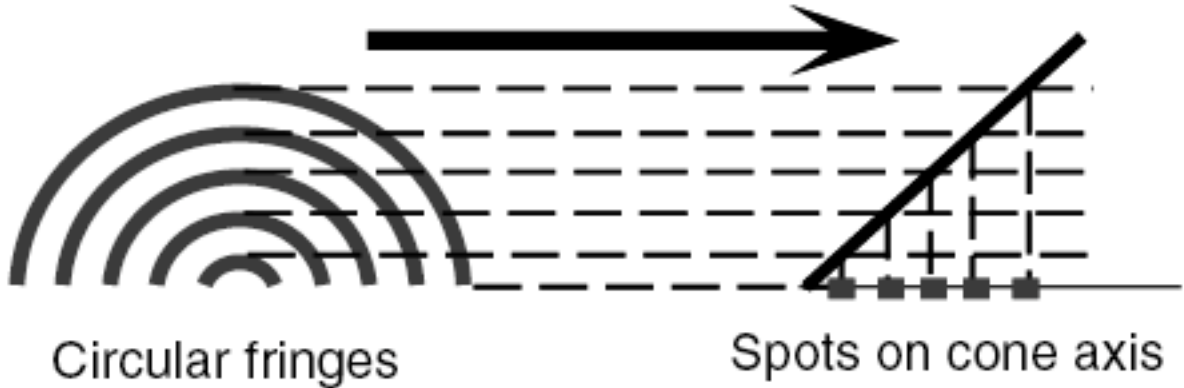
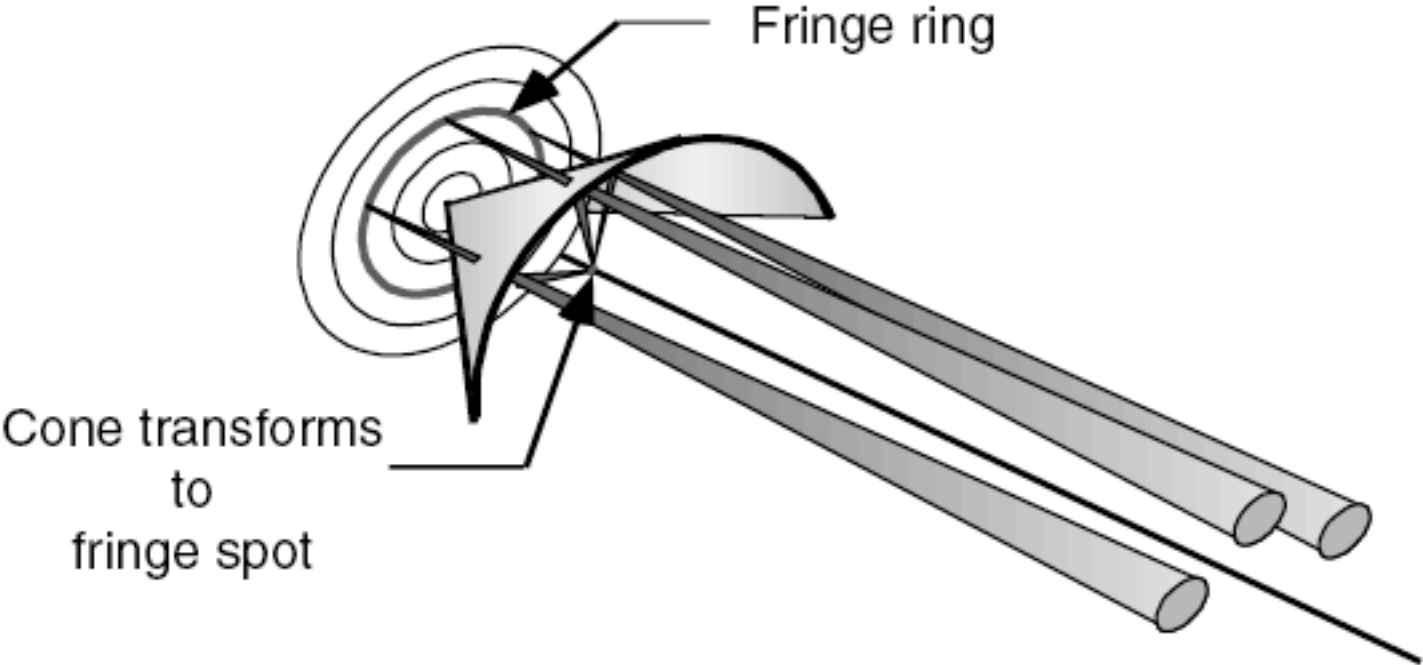

Improving Fringe-Imaging Efficiency

- ❑ When F-P etalon is used, only a portion of the incident light is transmitted through the interferometer, and majority of the incident light is reflected out. Three methods to improve this situation -
- ❑ **Fractional Fringe Illumination:** the etalon is illuminated by a solid angle corresponding to only a fraction of the full FSR, which can result in a significantly higher fraction of the signal being transmitted by the etalon.
- ❑ **Interferometer Photon Recycling:** reflected photons are collected by fibers and then re-illuminate the etalon.
- ❑ **Channel Photon Recycling:** the aerosol channel transmits the aerosol scattering while the light reflected from aerosol channel is fed to the molecular channel.

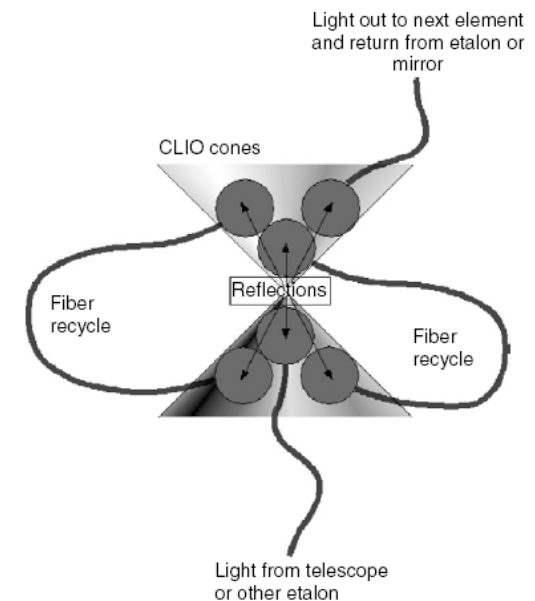
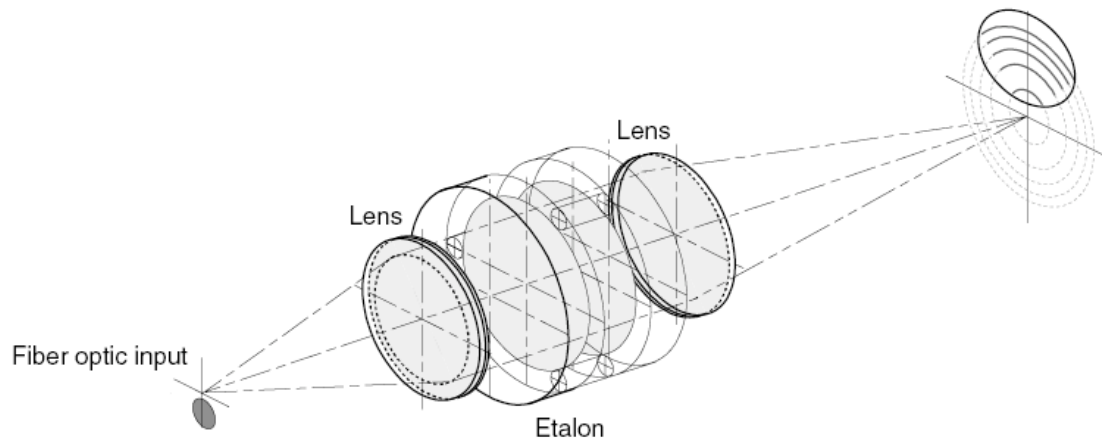

Photon Recycling + CLIO

End view of input

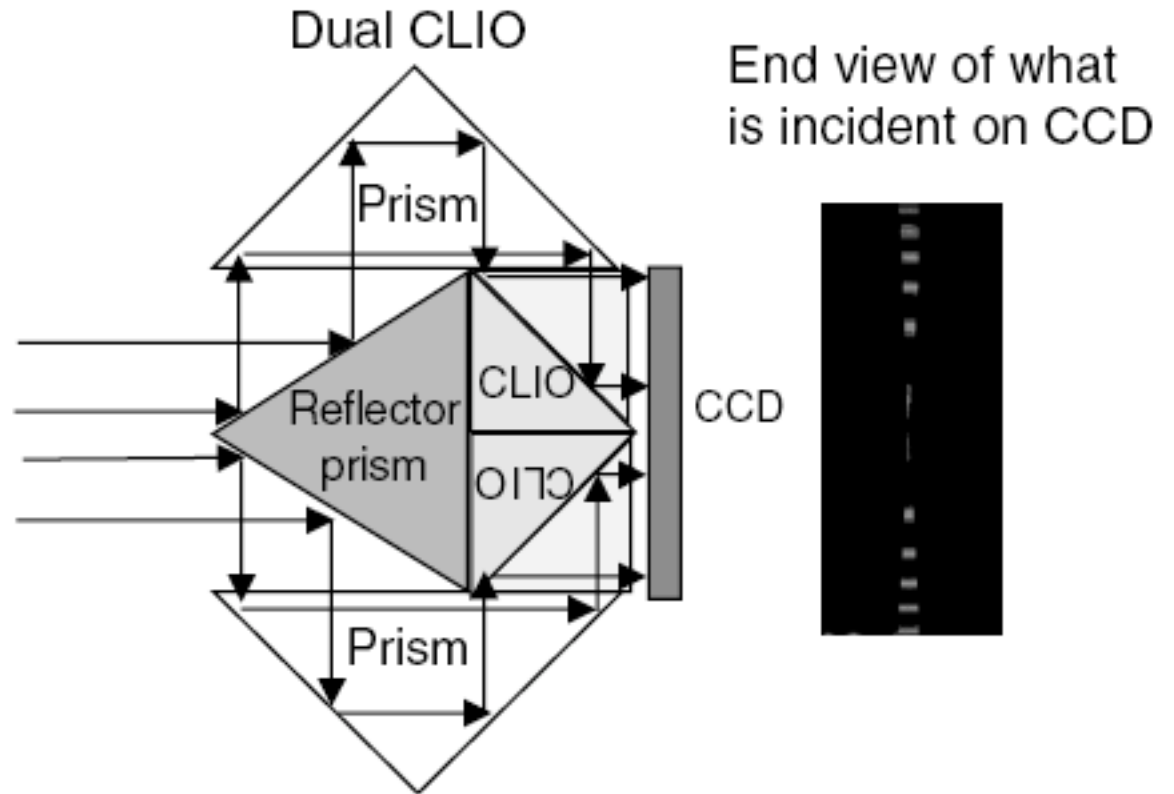

Example DDL: GroundWinds

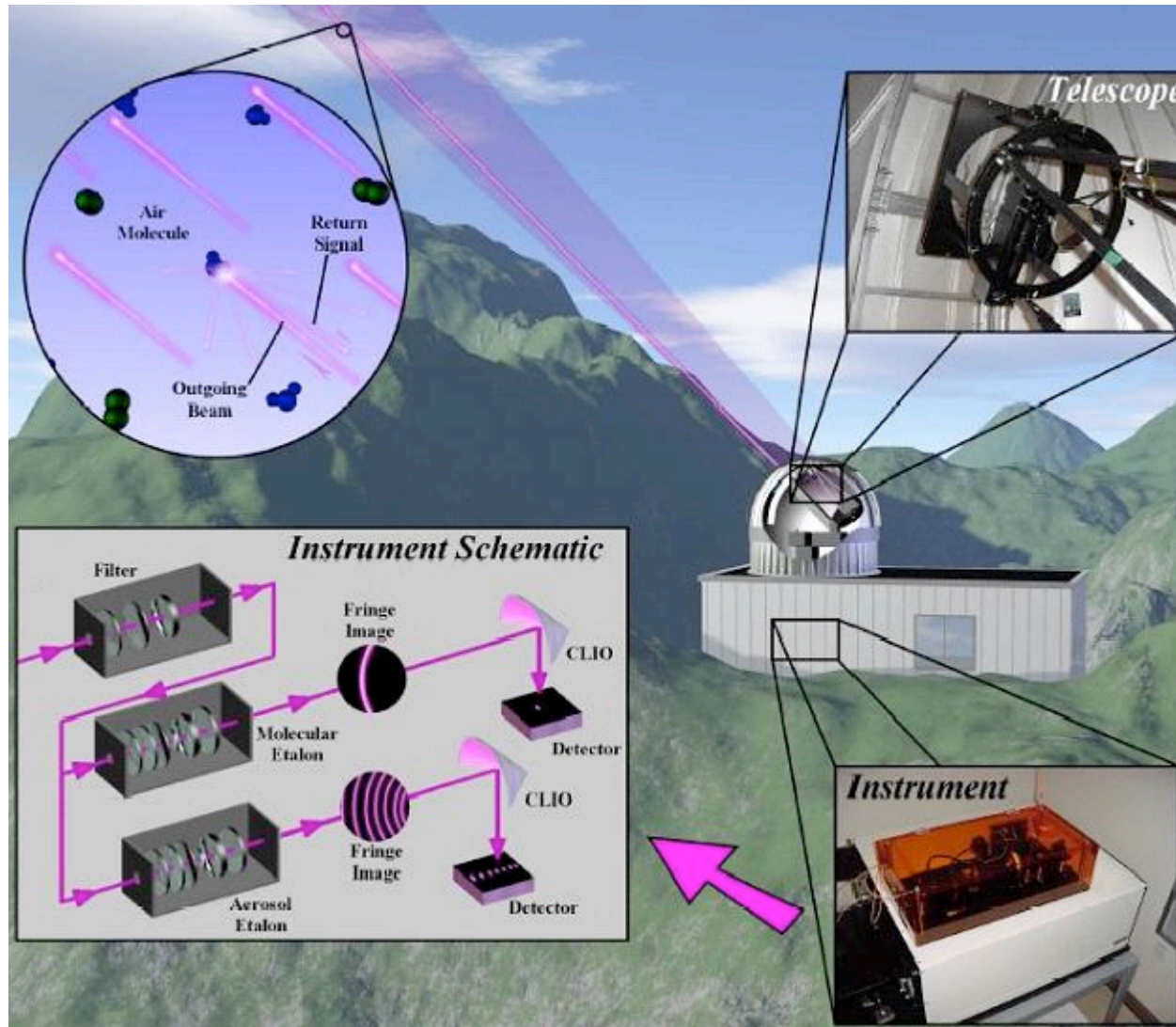

<http://groundwinds.sr.unh.edu/>

Scanning FPI DDL, FPI Edge-Filter DDL

- Tepley et al. [1993, 1994] demonstrated 15-60 km wind measurements using scanning FPI.
- However, it is likely that signals were from PMT saturation response, not real.
- More researchers turn attention to the edge-filter techniques.

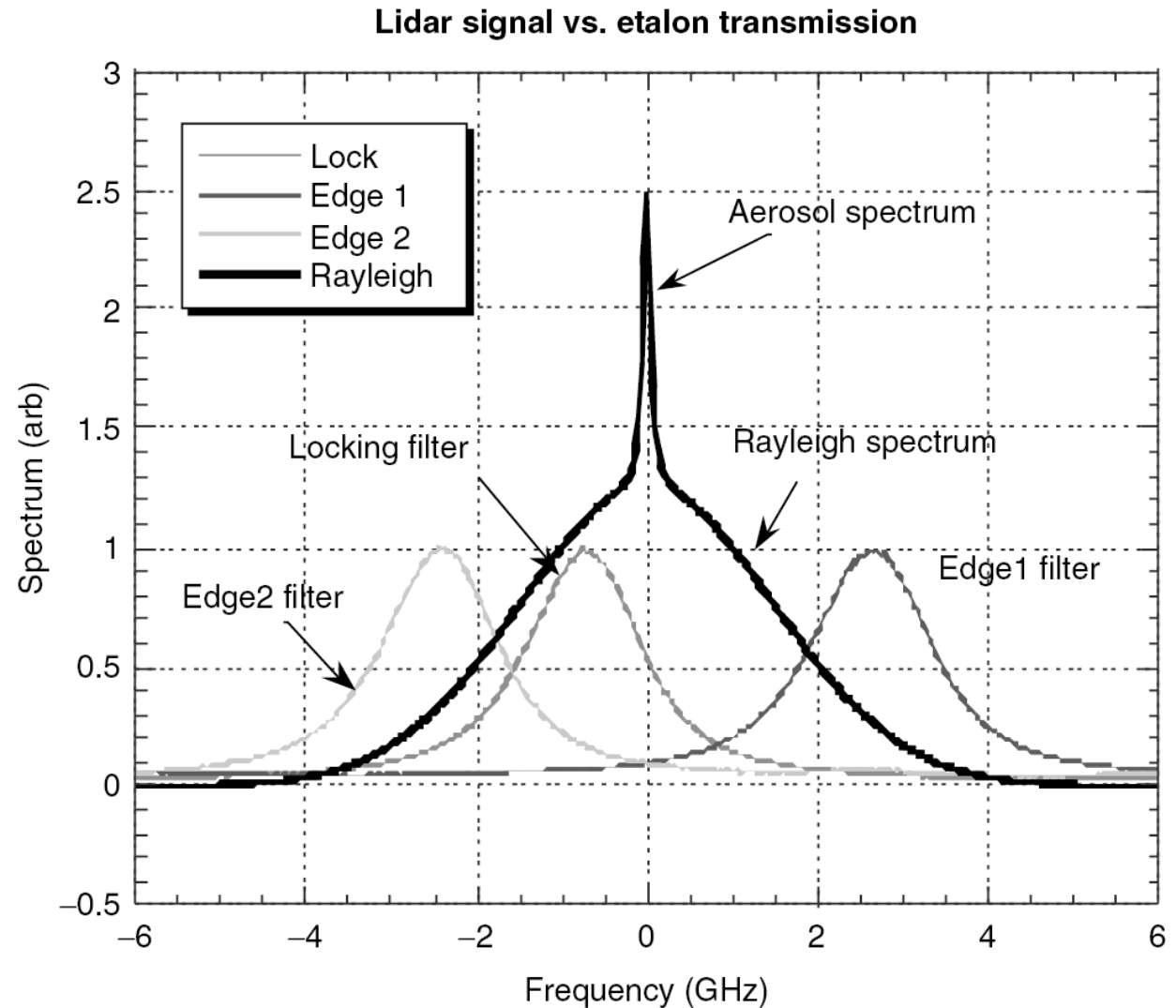

The locking filter channel is to ensure the optimum balance of the Edge 1 and Edge 2 filters (F-P etalons) on the zero Doppler-shifted laser signal.

Freq Analyzer: Single-Edge Filter

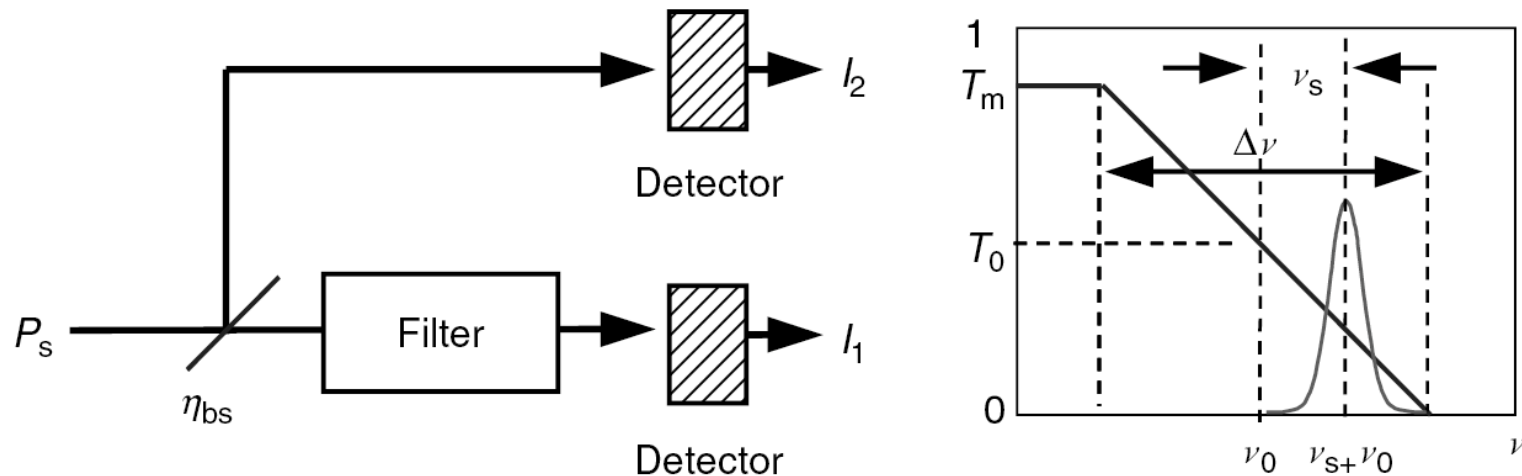

Figure 7.31 Single-edge functional diagram and filter transmission.

□ A Fabry-Perot etalon is usually employed as the edge filter. The etalon is locked to the zero-Doppler laser frequency, ν_0 , such that the frequency of the transmitted laser is matched to the mid-point of the quasi-linear transmission edge of the etalon.

□ The intensity ratio of these two channels is a function of the Doppler frequency shift ν_s .

$$\begin{aligned}
 S = I_1/I_2 &= \frac{\eta_{bs}}{(1 - \eta_{bs})} \frac{\mathcal{R}_1}{\mathcal{R}_2} T_s \\
 &= \frac{\eta_{bs}}{(1 - \eta_{bs})} \frac{\mathcal{R}_1}{\mathcal{R}_2} (T_0 - T_m \nu_s / \Delta \nu)
 \end{aligned}$$

Freq Analyzer: Double-Edge Filter

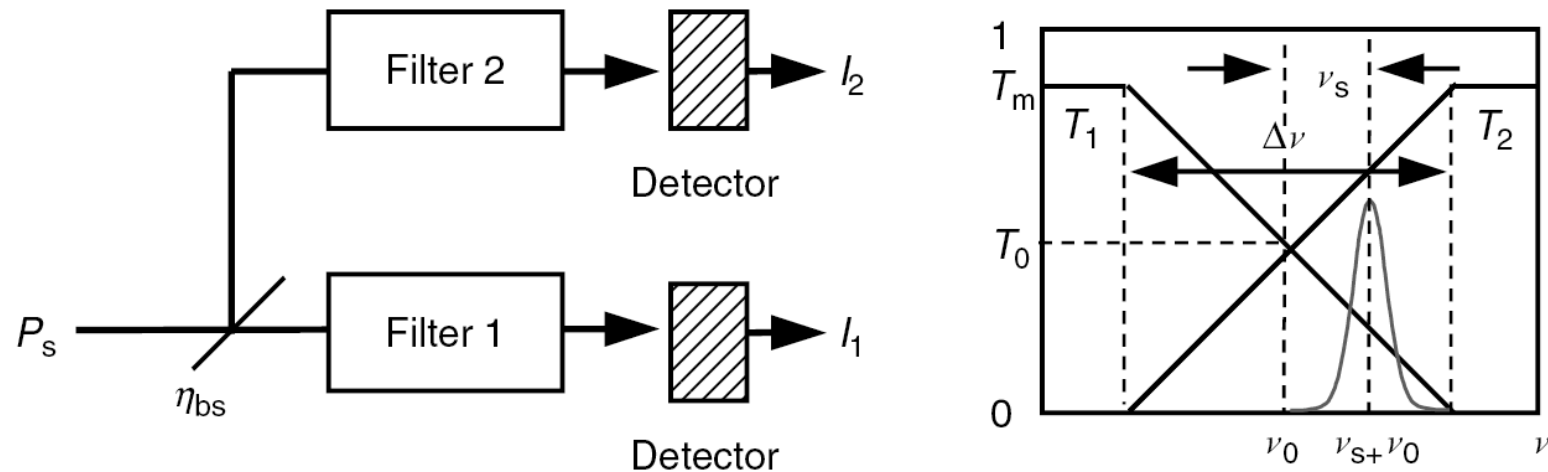

Figure 7.32 Double-edge functional diagram and filter transmission.

❑ Two oppositely sloped quasi-linear discriminator edges are used for the two receiver channels in the double-edge design. Usually etalon transmission fringes are used to create the edges. The etalons are locked together (mid-point) to the zero-Doppler transmitted laser frequency ν_0 .

❑ The intensity ratio of the difference between the two signals to the sum is a sensitive function of the Doppler frequency shift ν_s .

$$S = \frac{I_{\Delta}}{I_{\Sigma}} = \frac{I_1 - I_2}{I_1 + I_2} = \frac{T_{s_1} - T_{s_2}}{T_{s_1} + T_{s_2}} = \frac{2\nu_s}{\Delta\nu}$$

Detectors for FPI Edge-Filter DDL

- ❑ The information presented to the detector in an **edge detection** system is the image of the small on-axis solid angle corresponding to the central on-axis fringe of the Fabry-Perot etalon with the necessary spectral FWHM. A suitable detector will be one that has high quantum efficiency, low noise, the capability for photon counting or analog read-out, depending on the intensity of the signal, and which can be "time-gated" to provide range-resolved information.
- ❑ The conventional PMT, the APD, and the CCD are among several that have been used successfully, depending on the spectral region of the wind lidar. The PMT is a device that is essentially noise-free when used in photon-counting mode. Due to the negligible read-out and electronic noise, the PMT signal may be post-integrated with complete flexibility, leading to the PMT being widely used as a detector of choice, particularly at 355 and 532 nm. Its drawback is the modest quantum efficiency of the photocathode of the device, normally limited to values of order 40% or less, depending on the spectral region.
- ❑ **2-D detection: altitude range and time, similar to other lidars, except the fringe-imaging lidars.**

Fringe Imaging vs Edge Filters

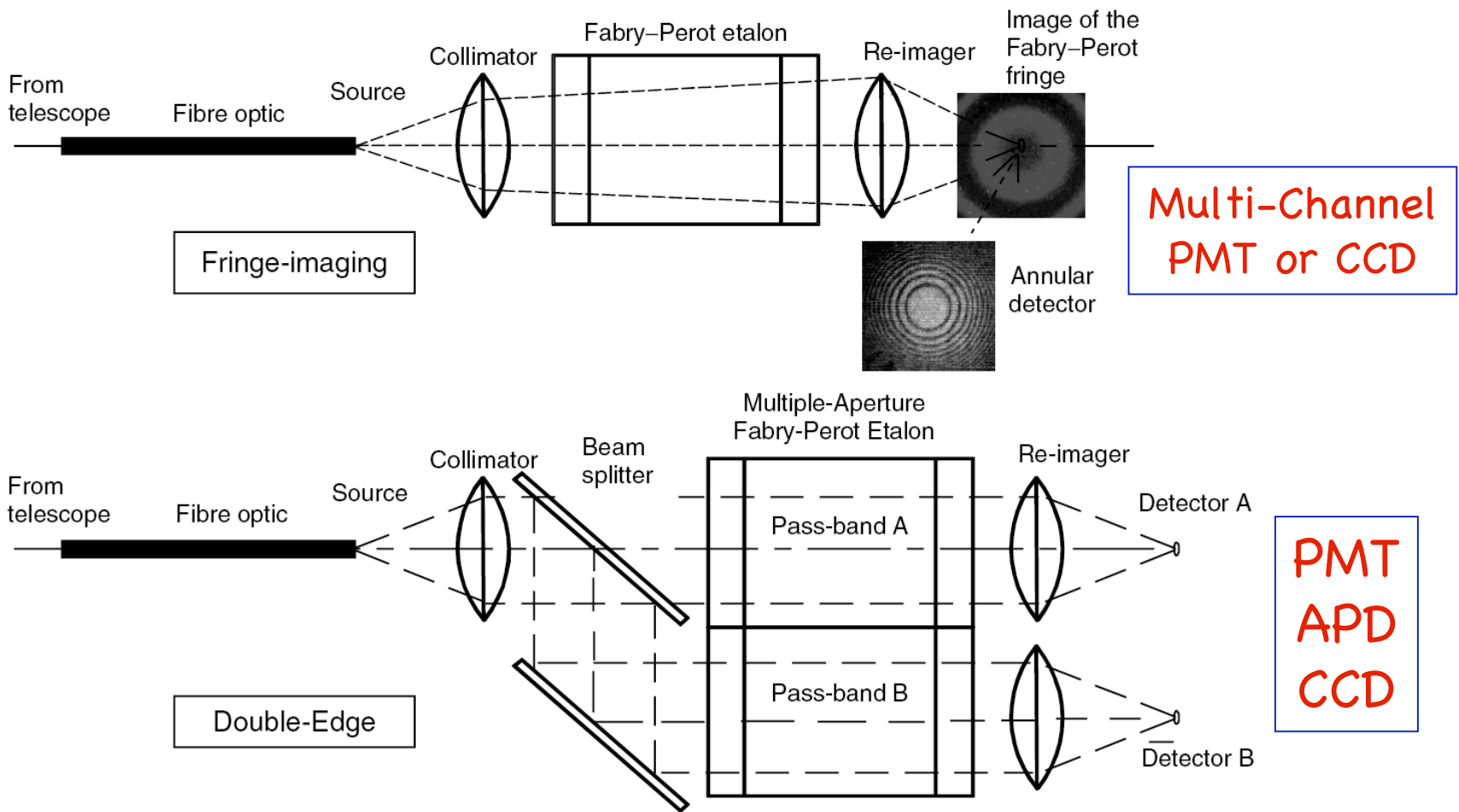

Figure 7.45 The fringe-imaging and double-edge detection methods for direct detection are shown conceptually.

I₂ Absorption Lines Edge-Filter DDL

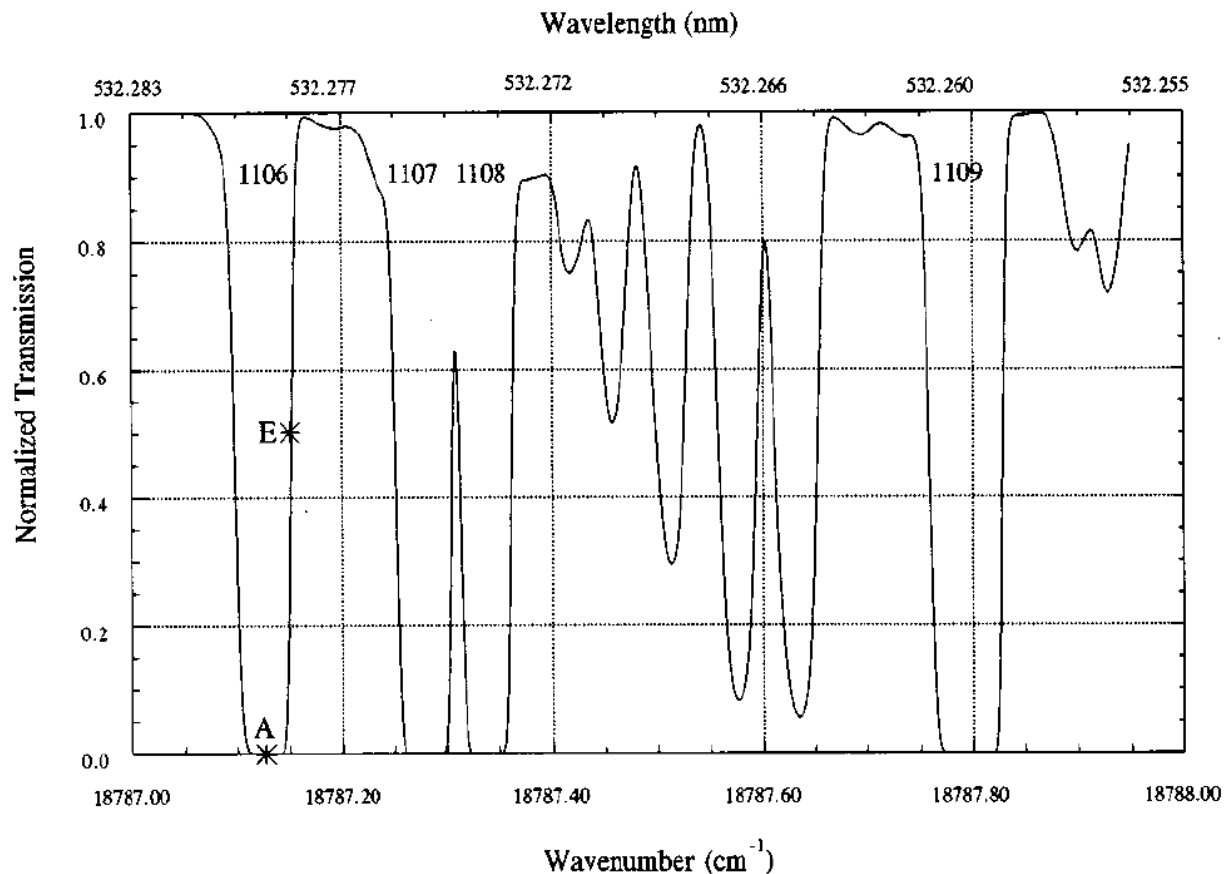

Fig. 2. Calculated transmission spectrum near 532 nm of a 10.2 cm long cell with cell and finger temperatures of 60 °C and 55 °C, respectively. The line 1106 shows the two points where the monolithic seed laser can be locked. By locking the laser at both points E and A and making measurements at each frequency, both the Doppler shift and the aerosol mixing ratio can be determined

[Liu et al., Appl. Phys. B 64, 561-566, 1997]

Iodine Absorption Lines near 532 nm

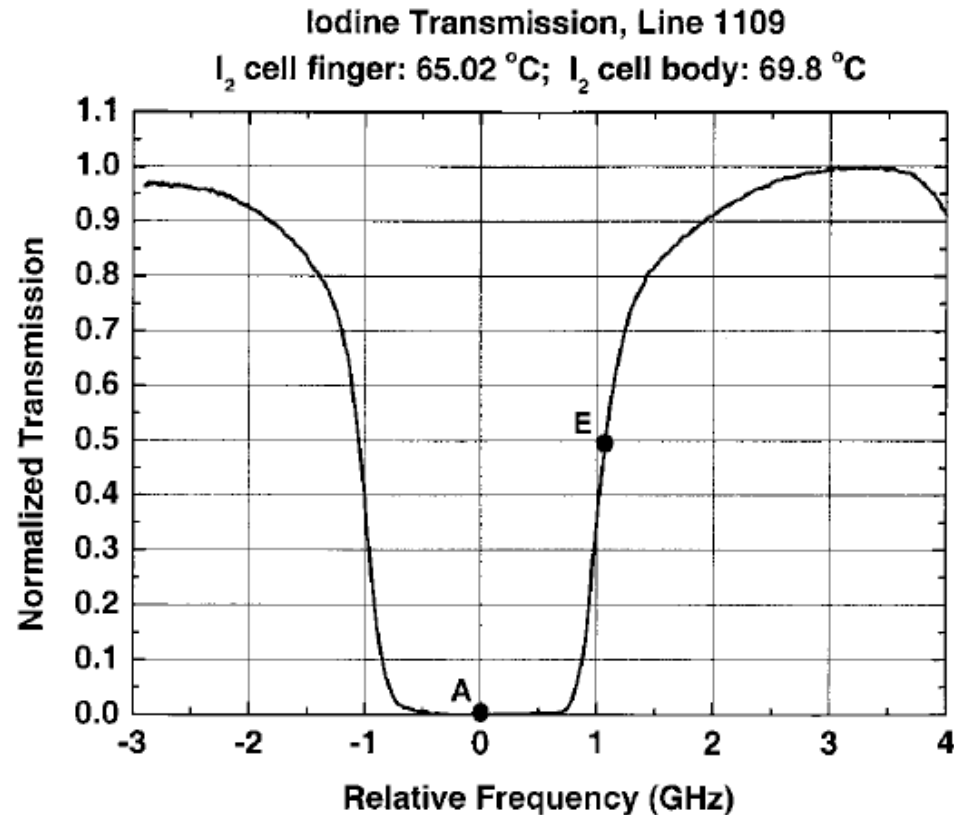

Fig. 2. Normalized transmission for absorption line 1109 of the iodine filter near 532 nm. The temperature of cell finger and cell body are 65.02 °C and 69.8 °C, respectively. The wave numbers at reference point A and locking point E are 18787.796 and 18787.830 cm^{-1} (1.02 GHz apart), respectively.

[Friedman et al., *Opt. Lett.*, 22, 1648–1650, 1997
Liu et al., *Appl. Opt.*, 41, 7079–7086, 2002]

DDL Instrumentation

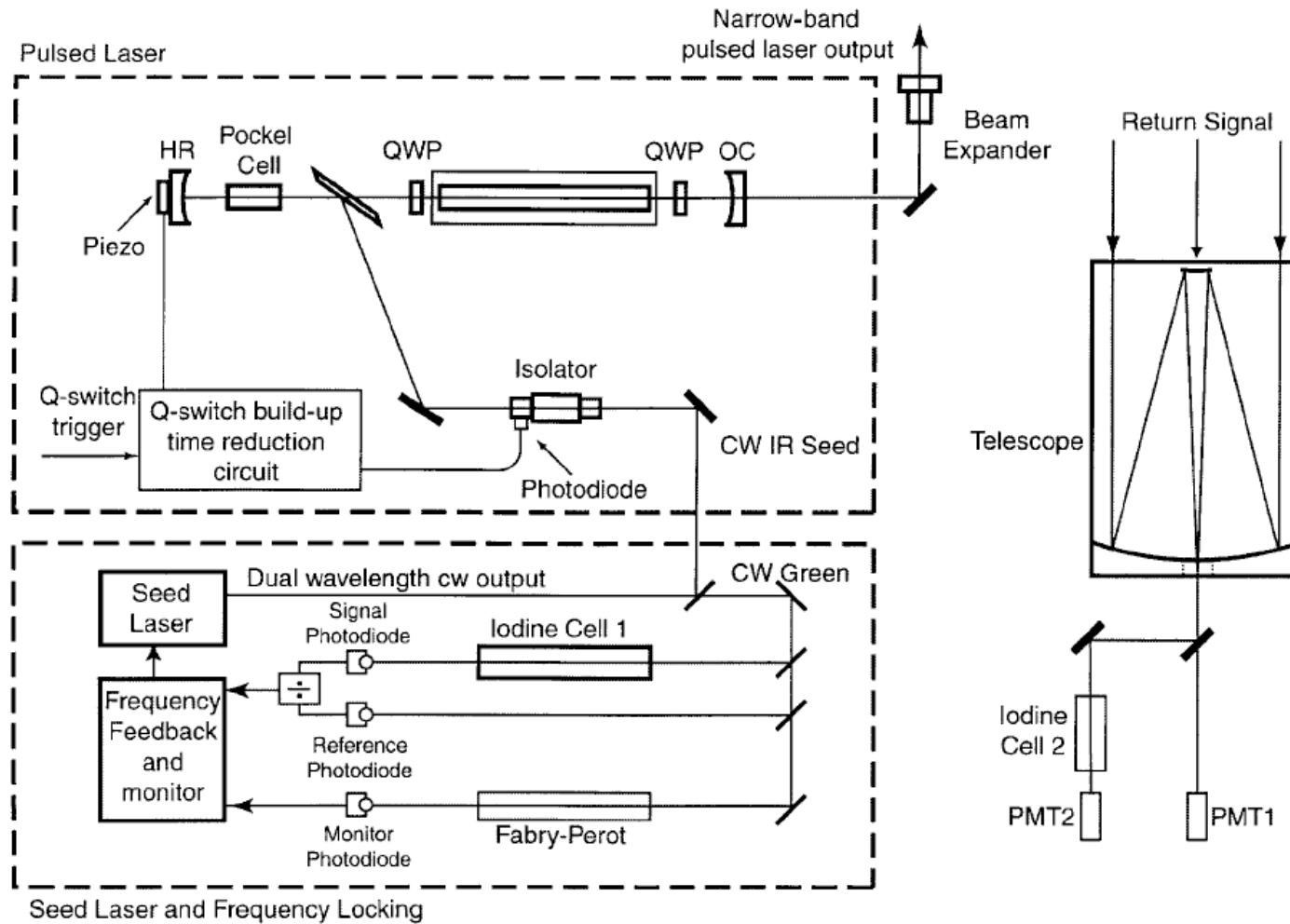

Fig. 1. Schematic diagram for injection-seeded Q-switched pulsed Nd:YAG laser transmitter on the left panels. The lidar receiver is shown on the right, where the iodine cell 2 is the frequency discriminator.

Papers on DDL wind measurements with a Cabannes-Mie lidar

- ❑ She et al., Appl. Opt., 46, 4434-4443, 2007: Comparison between iodine vapor filter and FPI
- ❑ She et al., Appl. Opt., 46, 4444-4454, 2007: impact of aerosol variations on the iodine filter methods
- ❑ There are several classic papers on the edge filter techniques providing good insight of the DDL techniques:
 - C. L.Korb, Bruce M. G. and C. Y. Weng, Edge technique: theory and application to the lidar measurement of atmosphere wind, Appl. Opt., 31, 4202-4212, (1992).
 - M. L. Chanin, A. Hauchecorne, A. Garnier and D. Nedeljkovic, Recent lidar developments to monitor stratosphere-troposphere exchange, J. Atom. Sol. Terr. Phys., 56, 1073-1081 (1994).
 - C. Flesia and C. L. Korb, heory of the double-edge molecular technique for Doppler lidar wind measurement, Appl. Opt., 38, 432-440 (1999).

Assumptions in Edge-Filter DDL

- ❑ To derive wind from edge-filter DDL, several quantities have to be taken from models or from independent measurements.
- ❑ Temperature profile: since the Doppler broadening (depending on temperature) affects the transmitted signal strength, it has to be pre-determined or taken from models for single or double-edge filters.
- ❑ Aerosol-scattering ratio also has to be determined independently when in the atmosphere region with aerosols. For example, in the I2 filter case, tuning the Nd:YAG laser to point A can eliminate aerosol signal thus deriving the aerosol scattering ratio when combined with the reference channel.
- ❑ Background counts in each channel.
- ❑ Of course, filter transmission functions have to be known and determined to high precision and accuracy.

Na/K Double-Edge Magneto-Optic Filter DDL

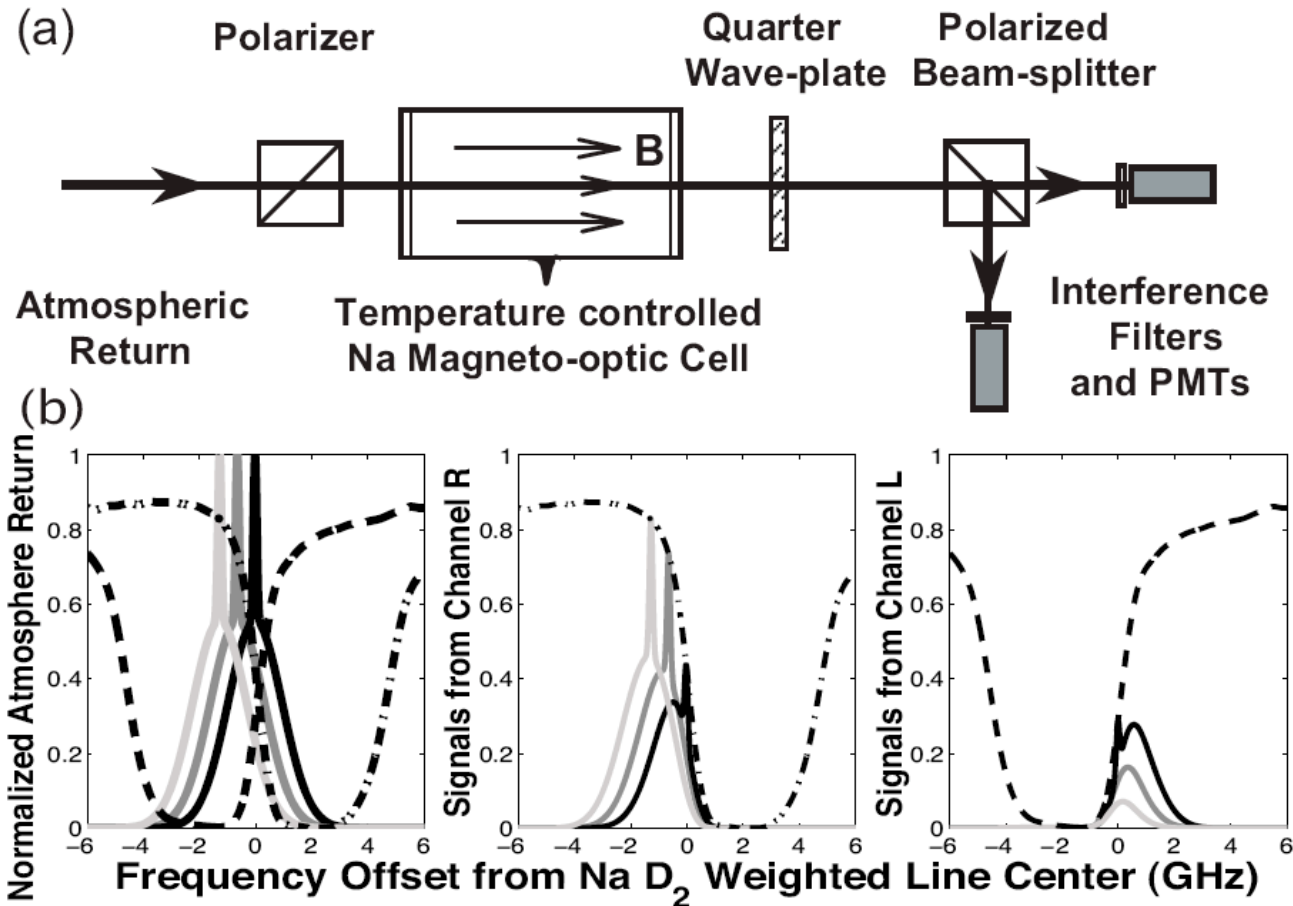

Na Double-Edge Magneto-Optic Filter (Na-DEMOMF)

□ With a 3-frequency Na or K Doppler lidar, it is possible to simultaneously measure wind, temperature, and aerosol with a Na-DEMOMF or K-DEMOMF.

New Development of DDL at 24th ILRC

- DDL based on Fizeau interferometer: linear fringes.
- Optical Autocovariance Wind Lidar (OAWL):

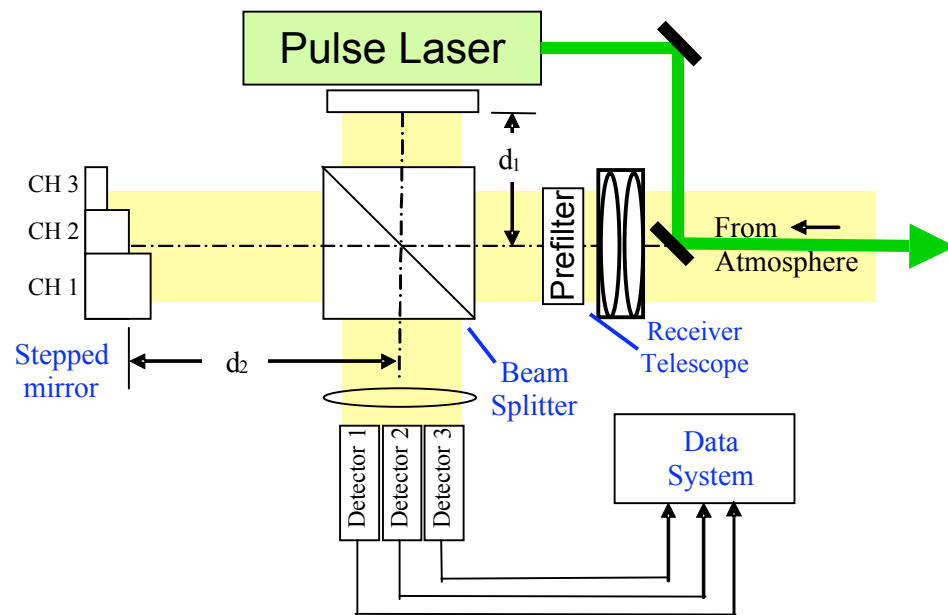

$$V = \lambda * \Delta\phi * c / (4 * (d_2 - d_1))$$

Measured as a fraction

Optical Autocovariance Wind Lidar

By Christian J. Grund et al., ILRC, 2008

Ball Aerospace patent pending

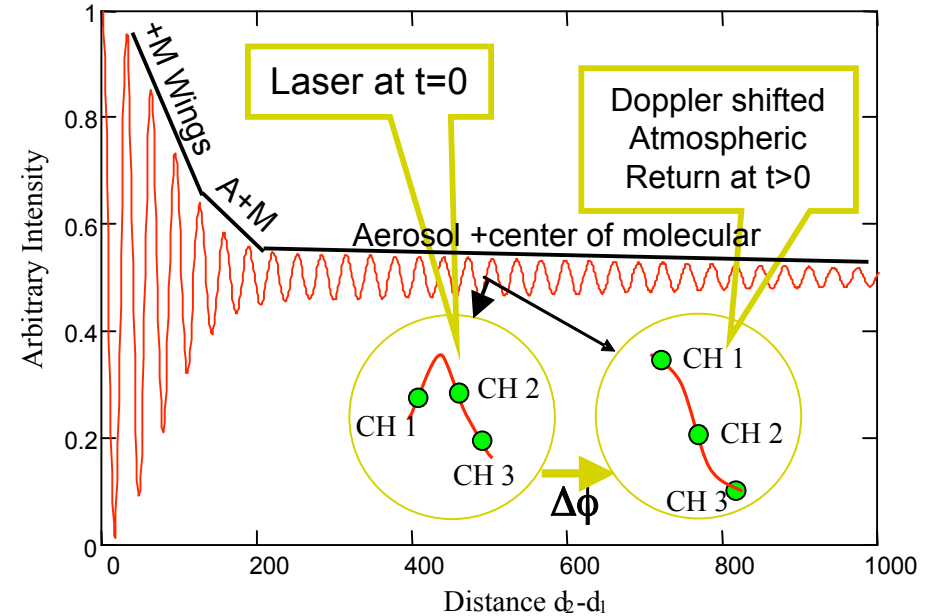
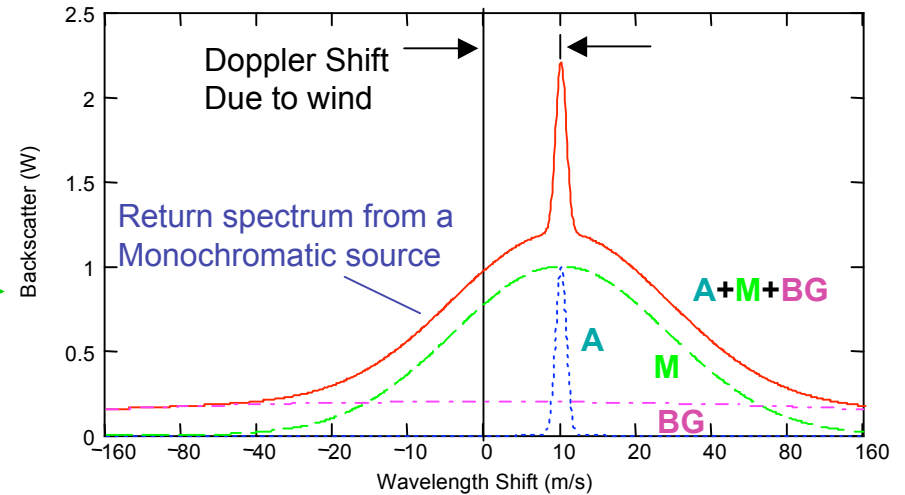

Comparison of Wind Techniques

Technique	Lidars	Applications
Doppler Wind Technique (Direct Detection or Coherent Detection): wind dependence of Doppler frequency shift (1 time Doppler shift for single absorption or emission process) (2 times Doppler shift for Mie and Rayleigh scattering)	Resonance Fluorescence Doppler Lidar: Doppler frequency shift and broadening of resonance fluorescence absorption cross-section (scan and ratio techniques)	Mesosphere and Lower Thermosphere temperature and wind (75-120 km); possible in thermosphere with other species
	Rayleigh/Mie Direct Detection Doppler Lidar : Doppler frequency shift of molecular and/or aerosol scattering using edge filters (absorption lines or etalons) or fringe imaging or scanning FPI or Michelson Interferometer	Lower mesosphere, stratosphere and troposphere wind (up to 50-60-70 km if there are enough photon counts)
	Coherent Detection Doppler Lidar: Doppler frequency shift of aerosol scattering using heterodyne detection technique	Troposphere wind, especially in boundary layers (up to 15 km), where aerosols are abundant
Direct Motion Detection Technique: derivative of displacement (the definition of velocity) (direct application of velocity definition or cross-correlation coefficient)	High-Spectral-Resolution Lidar: tracking aerosol / cloud motion through time	Troposphere wind, where aerosols and clouds are abundant
	(Scanning) Aerosol Lidar: tracking aerosol motion through time	Troposphere wind, where aerosols and clouds are abundant
	Laser Time-of-Flight Velocimeter: measuring time-of-flight of aerosol across two focused and parallel laser beams	Within the first km range, laboratory, machine shop, etc.
	Laser Doppler Velocimeter: measuring the frequency of aerosol scattering across the interference fringes of two crossed laser beams	Within the boundary layers, wind tunnel, production facility, machine shop, fluid mechanics research, etc

Summary

- ❑ Direct detection Doppler lidar uses atomic/molecular absorption lines, the edge filters, or fringe-imaging techniques to discriminate or analyze the frequency or spectrum of the return lidar signals (Doppler shifted and/or broadened). Potentially, DDL can measure both wind and temperature if sufficient spectral information is provided or inquired.
- ❑ For atmospheric science study, especially for waves coupling from lower to upper atmosphere, I think that DDLs have very high potentials for the future, especially the combination of resonance DDL in MLT region with non-resonance DDL in the troposphere, stratosphere and lower mesosphere, we may be able to profile the wind and temperature from ground all the way up to 120 km. This will be a breakthrough for atmospheric science community.

Please read our textbook Chapter 7 for direct-detection Doppler lidar and for coherent-detection Doppler lidar.